

G

Z

E

V

E

E

E

N

2007

Home Communications Products



Door Entry Controllers • Door Entry Phones
Video Entry Phones • Door Entry Enhancements
Whole House Paging • Enhanced Weather Protection

Manufactured in the USA / American Technical Support



CONTROLLERS - Page 3

ENTRY PHONES - Pages 4-5

VIDEO ENTRY PHONES - Page 6

ENHANCEMENTS - Page 7

How to Contact Us:

Information: 715.386.8861
 Online: www.vikingelectronics.com
 Email: info@vikingelectronics.com

All Viking products are in-stock nationwide through distributors listed on the back cover.

EWP and Installing a Viking Door Entry System

How to Connect a Viking Door/Gate Entry System to Your Existing Phones

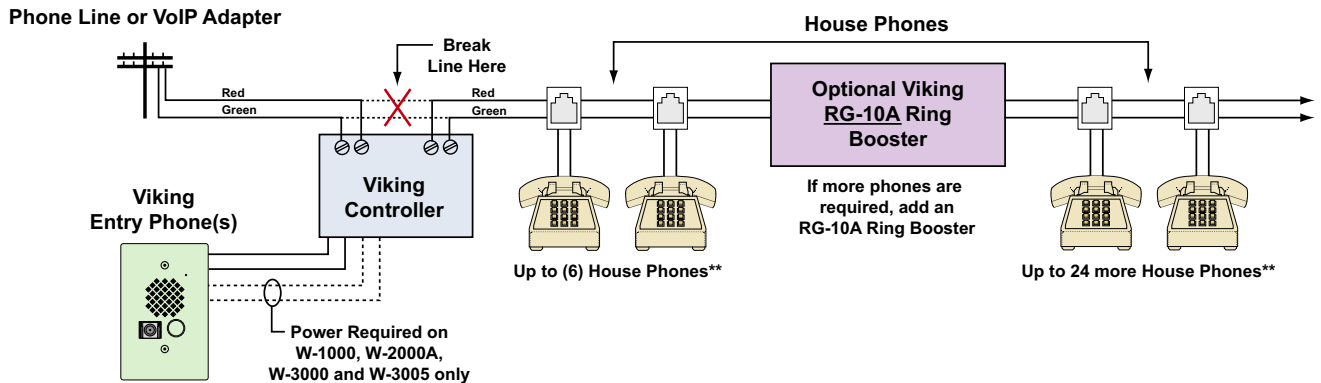

Entry Phones / Doorboxes	Use Controller	Max # Door Phones	Max # Doorstrikes	Entry Phone Caller ID	Keyless Entry
E-10A, E-20B, E-30, E-35*, E-40, E-50*	C-200	1	0	No	No
E-10A, E-20B, E-30, E-35*, E-40, E-50*, K-1700-3, K-1705-3*, K-1900-8	C-2000A	4	4	Yes	Yes
W-1000, W-2000A, W-3000, W-3005*	C-1000B	2	2	No	No

* Includes a built-in CCTV color camera, which requires additional wiring.

** Phones with 0.5 REN rating.

When to Use Viking Enhanced Weather Protection (EWP) Products

Viking EWP products are designed to be used in high-humidity, wet or exposed locations and corrosive or high pollution environments.

Typical applications include outdoor emergency or entry phones, roadside assistance and parking garage phones or phones located in salt-air environments near the ocean.

EWP product's electronics are encapsulated in clear urethane. The field adjustable trim pots and dip switches are sealed as are the LED, push button and microphone connections. The mylar speakers have a special weatherproof gasket. Finally, the weatherproof connectors are filled with an anti-corrosive sealing gel.

All EWP products conform to NEMA 3R requirements.

To order a Viking EWP product, add the suffix "-EWP" to the model number.

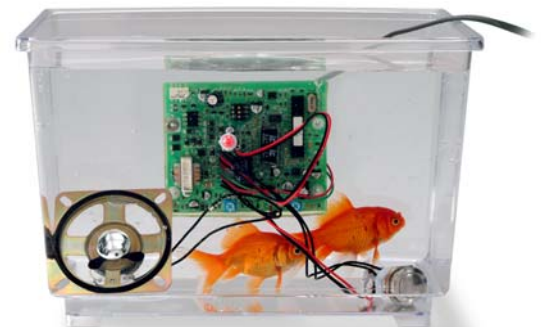

EWP product shown working underwater.

Single Entry Phone Controller - Model C-200

Allows Your House Phones or Phone System to Share a Phone Line / VoIP Adapter with a Single Viking Entry Phone

- House phones ring with C.O. line cadence or distinctive ring when the entry phone "Call" button is pressed
- Provide entry phone activated chimes and whole house paging when used with an SLP-1 Single Line Paging Controller (page 7)
- Produces double "Call Waiting" tones if the entry phone is activated when the house phones are already on a call
- One set of normally open and normally closed contacts available for operating a doorbell, camera, lights, etc.

Compatible with these Viking entry phones:

- E-10 (page 4)
- E-20A (page 4)
- E-30 (page 4)
- E-35 (page 6)
- E-40 (page 4)
- E-50 (page 6)



Model	Description
C-200	Single Entry Phone Controller

Advanced Door or Gate Entry Phone Controller - Model C-2000A

Allows Your House Phones or Phone System to Share a Phone Line / VoIP Adapter with up to 4 Viking Entry Phones

- House phones ring with C.O. line cadence or distinctive ring when the entry phone "Call" button is pressed
- Provide entry phone activated chimes and whole house paging when used with Viking model SLP-1 (page 7)
- Up to 6 different keyless entry codes / "one time use" keyless entry codes per entrance
- Up to 6 master keyless entry codes for use at any entrance
- Optional "Privacy Number" allows only selected visitors to call from an entry phone
- Provides entry phone "Caller ID" and "Call Waiting Caller ID"
- Produces "Call Waiting" tones
- Lighted doorbell switch input to activate entry phone call
- One set of normally open and normally closed contacts available for each entry phone
- Programmable contact activation time
- Auxiliary input to activate timed auxiliary contacts

Compatible with these Viking entry phones:

- E-10A (page 4)
- E-20B (page 4)
- E-30 (page 4)
- E-35 (page 6)
- E-40 (page 4)
- E-50 (page 6)
- K-1700-3 (page 5)
- K-1705-3 (page 6)

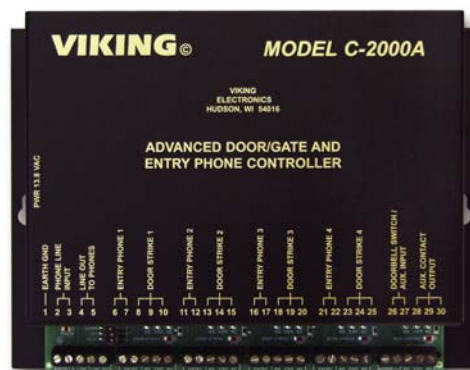

Model	Description
C-2000A	Advanced Entry Phone Controller

Door or Gate Doorbox and CCTV Camera Controller - Model C-1000B

Allows Your Residential or Business Phone System to Share a Phone Line / VoIP Adapter with 2 Viking Doorboxes

- Doorbox triggered CCTV camera switching
- House phones ring with C.O. line cadence or distinctive ring when the entry phone "Call" button is pressed
- Provides two Touch Tone controlled N.O. or N.C. dry contacts (5 amp rating) for door strikes or gate openers
- Keyless entry/postal lock input
- Built-in talk battery for "No C.O. Line" applications
- Auxiliary contact output for doorbells, lights, etc.

Compatible with these Viking doorboxes:

- W-1000 (page 5)
- W-2000A (page 5)
- W-3000 (page 5)
- W-3005 (page 5)



Model	Description
C-1000B	Doorbox & CCTV Controller

Handsfree Entry Phones - Models E-10A & E-20B

Phone Line / VoIP Adapter Powered Phones for Parking Ramps, Campuses and Door / Gate Entry

- Two-wire installation
- Auto-disconnects on CPC, silence, busy or dial tone
- Optional Enhanced Weather Protection (EWP) available
- Adjustable microphone and speaker volume
- Selectable auto-answer feature for remote monitoring
- Weather resistant features: mylar speaker, gaskets, internally sealed push button switch, UV stable exterior, enamel coated PCB
- Alternate action call button to place or cancel a call
- Surface mount box available for E-10A, model VE-5x5 (see page 7)
- E-10A dimensions: 5"W x 5"H x 2.2"D
- E-20B dimensions: 5.5"W x 4.5"H x 1.5"D

Use with these Viking controllers:

- C-200 (page 3)
- C-2000A (page 3)



E-10A



E-20B

Model	Description
E-10A	Flush Mount Entry Phone
E-20B	Surface Mount Entry Phone

Handsfree Emergency/Entry Phones with Dialer - Models E-30 & E-30-PT

Phone Line / VoIP Adapter Powered Phones Dial Pre-programmed Numbers

- Two-wire installation
- If the call is not answered, the E-30 will dial up to 4 more numbers
- E-30-PT has a push-to-talk button
- Vandal resistant, stainless steel faceplate with heavy-duty metal call button
- Non-volatile memory (no batteries required)
- Red off-hook LED indicator
- Auto-disconnects on CPC, silence, busy signal, dial tone, time out or a touch tone command
- Programmable to auto-answer on incoming calls
- Extended temperature range (-30°F to 150°F)
- Optional Enhanced Weather Protection available
- Dimensions: 5"W x 5"H x 2.2"D

Use with these Viking controllers:

- C-200 (page 3)
- C-2000A (page 3)

E-30 & E-30-PT shown in optional VE-5x5 surface mount box (page 7)



E-30-PT



E-30

Model	Description
E-30	Flush Mount Entry Phone
E-30-PT	Entry Phone with Push to Talk

Compact Handsfree Entry Phones - Model E-40

Phone Line / VoIP Adapter Powered Door Entry Phones with Consumer Styling - Commercial Quality

- Two-wire installation
- Extended temperature range (-30°F to 150°F)
- Compact size for flush mounting in a single gang box (with minimum inside dimensions of: 2"W x 2.84"H x 2.25"D)
- Weather and vandal resistant for outdoor locations
- Auto disconnect on CPC, busy, dial tone, silence OR...
- Press the call button again to disconnect
- Dimensions: 3.12"W x 4.87"H x 1.7"D
- VE-3x5 surface mount box available (see page 7)
- PNL-40 replacement faceplates available in 5 finishes

Use with these Viking controllers:

- C-200 (page 3)
- C-2000A (page 3)



Brushed Stainless Steel

Oil Rubbed Bronze

Polished Brass

Satin White

Satin Black

Model	Description
E-40-SS	Stainless Steel Entry Phone
E-40-BN	Oil Rubbed Bronze Entry Phone
E-40-PB	Polished Brass Entry Phone
E-40-WH	Satin White Entry Phone
E-40-BK	Textured Satin Black Entry Phone

Handsfree Entry Phone with Keypad - Model K-1700-3

Phone Line / VoIP Adapter Powered For Keyless Door and Gate Entry or Apartment Applications

- Vandal Resistant Features: 14 gauge, louvered, stainless steel faceplate with stainless steel speaker/mic screen, heavy duty metal keypad and "Call" button
- Optional Enhanced Weather Protection (EWP) available
- Microphone and speaker volume adjustments
- Advanced call progress detection: disconnects on busy signal, return to dial tone, CPC, reorder tone, maximum call time out and selectable silence time out
- Zinc plated steel rough-in box included with 3/4" conduit knockouts
- Selectable auto-answer feature and push button disconnect
- Yellow "in use" LED
- Selectable maximum call time
- Extended temperature range (-30°F to 150°F)
- Dimensions: 6.5"W x 5.5"H x 2.6"D

Use with these Viking controllers:

- C-200 (page 3)
- C-2000A (page 3)
- K-1900-3 (online)

K-1700-3 shown in optional VE-6x7 surface mount box (page 7)



Model	Description
K-1700-3	Handsfree Entry Phone with Keypad

Handsfree Doorboxes - Models W-1000 & W-2000A

Provides 24 Volt Talk Battery and 20 Hz Ring Generator for Phone System Unused Line Input Applications

- W-1000 Features: Flush mount, vandal resistant, black powder painted, aluminum face plate with heavy duty metal call button, mounting gasket and rough-in box
- W-2000A Features: Light gray colored, impact resistant, U.V. stable, plastic surface mount chassis
- Optional Enhanced Weather Protection (EWP) available
- Extended temperature range (-30°F to 150°F)
- High output speaker amplifier with volume adjustment
- Microphone and speaker volume adjustments
- Selectable number of rings (2, 3, 10 or 30)
- Surface mount box available for W-1000, model VE-5x5 (see page 7)
- W-1000 dimensions: 5"W x 5"H x 2.2"D
- W-2000A dimensions: 5.5"W x 4.5"H x 1.5"D

Use with this Viking controller:

- C-1000B (page 3)



W-1000



W-2000A

Model	Description
W-1000	Flush Mount Doorbox
W-2000A	Surface Mount Doorbox

Stainless Steel Handsfree Doorbox - Model W-3000 & W-3005

Provides 24 Volt Talk Battery and 20 Hz Ring Generator for Phone System Unused Line Input Applications

- Vandal resistant, 14 gauge stainless steel faceplate, heavy-duty metal push button and mounting gasket
- W-3005 has built-in color CCTV camera (see page 6 for complete camera specifications)
- Flush mount using the included rough-in box
- Selectable "Push-to-Talk" feature for noisy environments
- Extended temperature range (-30°F to 150°F)
- Optional Enhanced Weather Protection (EWP) available
- Yellow call progress/night light LED
- High output speaker amplifier with volume adjustment
- Microphone and speaker volume adjustments
- Selectable distinctive ring (standard or 2 short rings)
- Selectable number of rings (2, 3, 10 or 30)
- Compact 45° terminal strip for easy wiring
- Dimensions: 5"W x 5"H x 2.2"D

Use with this Viking controller:

- C-1000B (page 3)

W-3000 & W-3005 shown in optional VE-5x5 surface mount box (page 7)



W-3005



W-3000

Model	Description
W-3000	Stainless Steel Doorbox
W-3005	Stainless Steel Video Doorbox

Entry/Emergency Phone with Dialer and Color Video Camera - Model E-35

All the Features of the E-30 (page 4) Plus a Color CCTV Camera

- Built-in CMOS camera with 420 lines of resolution
- Audio and video transmission on one CAT5E cable*
- Extended temperature range (-30°F to 150°F)
- Optional Enhanced Weather Protection (EWP) available
- Optional surface mount box available, model VE-5x5 (see page 7)
- Dimensions: 5"W x 5"H x 2.2"D

Use with these Viking controllers:

- C-200 (page 3)
- C-2000A (page 3)

E-35 shown in optional VE-5x5 surface mount box



Model	Description
E-35	Video Entry Phone with Dialer

Camera Specifications

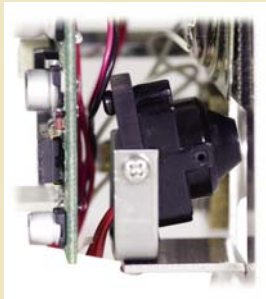

Tilt camera up or down, swivel camera left or right, lock in place!

Power: 5-9V DC regulated 150mA (6V DC adapter included)

Tilt/Swivel Adjustment: Vertical +/- 20°, horizontal +/- 30°

Image Sensor: 1/4" color CMOS

Video Output: 1 VP-P composite, NTSC, 75 ohms

Resolution: 420 lines (640 x 480 / 307,200 pixels)

Sensitivity: 0.26 LUX (20 IRE) F2.0

Lens: 3.4mm, pinhole 70°FOV

*Maximum Wire Run Length: 150 ft on CAT5E, 1000 ft with RG59 and CAT5

Entry Phones with Color Video Camera - Model E-50

All the Features of the E-40 (page 4) Plus a Color CCTV Camera

- Audio and video transmission on one CAT5E cable*
- 5 attractive colors - see E-40 colors (page 4)
- Extended temperature range (-30°F to 150°F)
- Compact size for flush mounting in a single gang box (with minimum inside dimensions of: 2"W x 2.84"H x 2.25"D)
- Weather and vandal resistant for outdoor locations
- Optional Enhanced Weather Protection (EWP) available
- Intelligent auto disconnect on CPC, busy, dial tone or silence
- Surface mount box available, model VE-3x5 (see page 7)
- Replacement faceplates available, model PNL-50 in all five finishes
- Dimensions: 3.12"W x 4.87"H x 1.7"D

E-50-SS



Use with these Viking controllers:

- C-200 (page 3)
- C-2000A (page 3)

Model	Description
E-50-SS	Stainless Steel Video Entry Phone
E-50-BN	Oil Rubbed Bronze Video Entry Phone
E-50-PB	Polished Brass Video Entry Phone
E-50-WH	Satin White Video Entry Phone
E-50-BK	Textured Satin Black Video Entry Phone

Vandal Resistant Video Entry Phone with Keypad - Model K-1705-3

All the Features of the K-1700-3 (page 5) Plus a Color CCTV Camera



K-1705-3 shown in optional VE-6x7 surface mount box (page 7)

Use with these Viking controllers:

- C-200 (page 3)
- C-2000A (page 3)

- Extended temperature range (-30°F to 150°F)
- Audio and video transmission on one CAT5E cable*
- Optional Enhanced Weather Protection (EWP) available
- Yellow "in use" LED
- Microphone and speaker volume adjustments
- Advanced call progress detection: disconnects on busy signal, return to dial tone, CPC, reorder tone, maximum call time out and selectable silence time out

Model	Description
K-1705-3	Video Entry Phone with Keypad

Door Entry Housings

Weather Resistant Surface Mount Boxes and Accessories



VE-GNP

Compatible with: VE-5x5 and VE-6x7



VE-3x5

Compatible with: E-40 and E-50



VE-5x5

Compatible with: E-10A, E-30, E-35, E-30-PT, W-1000, W-3000 & W-3005



VE-6x7

Compatible with: K-1700-3 and K-1705-3



VE-5x5-PNL



VE-6x7-PNL

The VE-PNL's are backboxes with a blank aluminum panel. The kits come complete with box, gasket, panel and screws.

Add bright LED illumination to doorboxes and entry phones (shown with E-30 & VE-5x5).



VE-LIGHT

Compatible with: VE-5x5 and VE-6x7

Model	Description
VE-3x5	Surface Mount Backbox
VE-5x5	Surface Mount Backbox
VE-6x7	Surface Mount Backbox
VE-5x5-PNL	Surface Mount Box with Panel
VE-6x7-PNL	Surface Mount Box with Panel
VE-GNP	Gooseneck Pedestal
VE-LIGHT	Lighting Kit

Door Entry Housings and Accessories

Talk Battery Booster- Model TBB-1A

Boost Talk Battery Voltage Up To 40 VDC

- Boost loop current up to 26mA
- Easy modular installation
- POWER LED also displays activity
- Passes original ringing to the device
- Passes caller ID data
- Passes hook switch flash
- Passes CPC signals
- Compatible with touch tone dialing

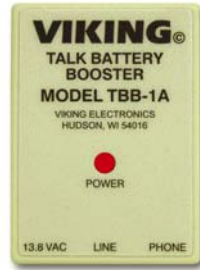

Model	Description
TBB-1A	Talk Battery Booster

Ring Booster- Model RG-10A

Boosts Ring Voltage on Phone Lines or VoIP Adapters

- Ring up to 24 more 0.5 REN phones
- Caller ID compatible
- Modular installation
- Compatible with distinctive ring
- Will not affect normal line operation
- Reshapes troublesome square wave ringing



Model	Description
RG-10A	Ring Booster

Single Line Paging Controller - Model SLP-1

Add Whole House Paging, Phone-to-Phone Intercom and Door Chimes to Your Multi-Room Audio System

- Stereo pre-amp input and line level output for whole house audio controllers
- Built-in two-watt mono paging amplifier with gain control
- Phone to phone intercom
- Place callers on music on hold while paging
- Can provide background music from an external source
- Selectable loud ringing and doorbell switch input
- Unique front and back door chimes when used with a Viking C-1000B or C-2000A
- Switch selectable On-Hold alarm tones

Compatible with these Viking controllers:

- C-200 (page 3)
- C-1000B (page 3)
- C-2000A (page 3)



Model	Description
SLP-1	Single Line Paging Controller

Home Communications Products

Commercial Quality

Viking Electronics knows how to design communications products that perform under all conditions - we've been doing it that way for over 35 years. Attention to detail is why commercial property managers and residential home owners alike depend on Viking products to perform, heat or cold, rain or shine.

Affordable

We encourage you to compare the price, quality and features of our products to the competition. We know you'll find that when it comes to quality construction and reliability, Viking's communication products offer the best value.

Consumer Styling

It's been hard to find commercial quality communications products styled for residential applications - until now. Viking's door entry phones sport an industry-first; single-gang compact footprint, making them the perfect choice for residential applications where mounting space is at a premium.

For a full-line product catalog, please contact Viking at 715-386-8861 or online: www.vikingelectronics.com

Viking products are in stock at the following distributors:

Graybar
800-825-5517 • www.graybar.com

ADI
800-233-6261 • www.adilink.com

Anixter
800-323-8167 • www.anixter.com

Jenne Distributing
800-422-6191 • www.jenne.com

TeleDynamics Corporation
800-847-5629 • www.teledynamics.com

Target Distributing
800-873-5528 • www.targetdist.com

Windstream Supply
800-533-3161 (US/CANADA)
www.windstreamsupply.com

Communications Supply
800-786-9584 • www.gocsc.com

Hall Telecommunications
519-822-5420 • www.halltel.com
800-265-2667 (CANADA)

Goldcom, Inc.
800-788-8848 • www.Gold-com.com

Capitol Sales
800-467-8255 • www.capitolsales.com

NTD Distributors
800-426-1024 • www.ShopNTD.com

HB Distributors
800-266-3478 • www.HBdistributors.com

High Tech Communication
800-256-3010 • www.high-techcomm.com

Power & Telephone
800-238-7514 • www.ptsupply.com

International Sales: Viking International
612-331-3823 • www.vikingelectronics.com

Viking Electronics, Inc.
1531 Industrial Street
Hudson, Wisconsin 54016
Printed in the USA

Address Service Requested

PRSR STD
U.S. POSTAGE
PAID
LA CROSSE, WI
PERMIT NO. 25