

VIKING PRODUCT MANUAL

COMMUNICATION & SECURITY SOLUTIONS

Handsfree Speaker Phone with Built-In Auto-Dialer and Color Video Camera

The **E-35** is a weather and vandal resistant handsfree video phone designed to provide quick and reliable handsfree communication and CCTV video of who is at your door or gate. The **E-35** can be connected directly to a C.O. line, analog PABX/KSU station, or a Viking Door/Gate Controller: **C-200**, **C-250** or **C-2000B**.

The **E-35** features non-volatile memory, a built in dialer, a built-in high resolution color video camera, and intelligent call progress detection for automatic hang-up when the call is completed.

The **E-35** can be programmed to dial up to 5 different numbers on ring no answer or busy and can be configured to dial these numbers until answered.

The **E-35-EWP** shares all of the features of the **E-35** in addition to Enhanced Weather Protection (EWP) for outdoor installations where the unit is exposed to precipitation or condensation. EWP products feature foam rubber gaskets, sealed connections, gel-filled butt connectors, as well as urethane or thermal plastic potted



E-35 / E-35-EWP
Brushed 316 Stainless Steel



E-35 shown with
optional **VE-5x5**

circuit boards with internally sealed, field-adjustable trim pots and DIP switches for easy on-site programming. For more information, see **DOD 859**.

Features

- **New Automatic Noise Cancelling feature for proper operation in noisy environments**
- Built-in 5 number auto-dialer
- Built-in high resolution color video camera with wide viewing angle, tilt/swivel adjustments and wide operating temperature
- Audio and video transmission on one CAT5E cable (page 5)
- **Vandal Resistant Features:** 14 gauge louvered 316 stainless steel faceplate with permanent laser etched graphics, stainless steel speaker/mic screen, heavy duty metal "Call" button, impact and scratch resistant camera lens and hex drive mounting screws
- **Weather Resistant Features:** Marine grade 316 stainless steel faceplate, Mylar speaker, faceplate gasket, mic and speaker gasket, internally sealed (IP67) push button switch, sealed camera lens, potted camera circuit board, stainless steel phone and camera mounting hardware
- **E-35-EWP** is designed to meet IP66 Ingress Protection Rating (see **DOD 859** for more information)
- Blue "off-hook" LED
- Volume adjustments for microphone and speaker
- **Advanced call progress detection:** disconnects on busy signal, return to dial tone, CPC, reorder signal, maximum call time out and selectable silence time out
- Selectable auto-answer feature for monitoring
- Selectable push button disconnect
- Optional **VE-5x5** surface mount box available
- Selectable maximum call time
- Selectable VOX switching speed
- Optional **PB-1** Panic Button Kit (**DOD 233**)

Applications

Gate and Door Entry Phones for:

- Business lobbies
- Residences
- Auto or pedestrian gates

Non-ADA Hot-Line Phones for:

- Elevators
- Stadiums
- Parking lots/ramps
- Convention centers
- ATM machines
- Silent holdup alarm dialer using optional Panic Button Kit

CAUTION - When installing on an analog extension of a phone system: Some phone systems do not conform to analog telecom standards and might not be compatible with the **E-35** speaker phones. For a detailed description of the telephone line specifications required for any of the **E-35** phones, see **DOD# 869**.

Note: In louder background noise environments, the push to talk version may be required (**E-30-PT** or **E-30-PT-EWP**).

Specifications

Dimensions: Overall-5" x 5" x 2.25" (127mm x 127mm x 57mm), Plastic Electrical Box-4" x 4" x 2.12" (102mm x 102mm x 54mm)

Shipping Weight: 2 lbs (0.9 Kg)

Operating Temperature: -30°F to 150°F (-34°C to 65°C)

Connections: (5) gel-filled butt connectors (3M Scotchlok UR2)

(See page 2 for complete specifications)

Information: 715-386-8861
www.VikingElectronics.com

Specifications

Entry Phone Specifications

Power: Telephone line powered. Minimum 24V DC talk battery voltage, with a minimum loop current of 20mA loop. Loop current may be boosted on low current lines with a Viking Model **TBB-1B** talk battery booster (**DOD# 632**).

Dimensions: Overall: 5" x 5" x 2.25" (127mm x 127mm x 57mm), Plastic Electrical Box: 4" x 4" x 2.12" (102mm x 102mm x 54mm)

Speaker Volume: Approximately 70 db maximum @1m

Ring Voltage: 25V AC RMS minimum (for auto answer)

CPC Disconnect Time: 500ms minimum

REN #: 0.5 A

Camera Specifications

Power: 6-22V DC 150mA (12V DC UL Listed adapter included)

Image Sensor: 1/4" color CMOS

Video Output: 1 VP-P composite, NTSC, 75 ohms

Resolution: 420 lines (640 x 480 @ 30fps / 307,200 pixels)

Sensitivity: 0.025 LUX (50 IRE) F 1.2 3200K

Lens: 2.1mm, conical pinhole

FOV (Field of View): 80° Horizontal, 60° Vertical, 100° Diagonal

Tilt/Swivel Adjustment: Vertical +/- 20°, horizontal +/- 30° (see **Diagram A**)

IR Compatibility: This camera is equipped with an OLP (Optical Low Pass) filter to maintain correct video color in outside applications. The standard camera is **NOT** compatible with IR illuminators. If IR illumination is required, you will need to replace the existing camera with a Viking model **VCAM-1IR**. For more information, see **DOD# 190**.

Maximum Wire Run Length: 1000 ft with *RG59/RG6 for video and CAT5 for power (1 pair) and entry phone audio (1 pair). 150 ft with CAT5E for video, power and entry phone audio (longer video runs are possible by using video balun transceivers, see **Installation C, 2, page 5**).

* **Note:** RG59 or RG6 with solid center conductor and 95% bare copper braid shield.

Entry Phone / Camera Specifications

Humidity: Standard model: 5% to 95% non-condensing, EWP model: Up to 100%

Shipping Weight: 3.5 lbs (1.6 kg)

Connections: (5) gel-filled butt connectors (3M Scotchlok UR2)

Recommended Surface Mount Box: Viking model **VE-5x5**, see **DOD 424** for more information.

Diagram A
Camera Horizontal Field of View:

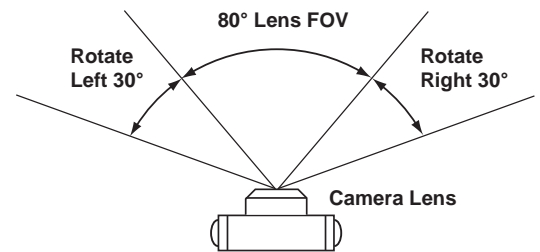

Features Overview

Mounting Screws: (4) 6-32 x 3/4" Marine grade 316 stainless steel, flat head, T-10 Torx Security Screws and Drive Bit (included)

Faceplate: 14 gauge Marine grade 316 stainless steel faceplate.

Color Video Camera: Wide operating temperature range of -30°F to 150°F, NTSC composite video output with 420 lines of resolution, 70° wide viewing angle lens, tilt and swivel adjustments for aiming towards visitors.

Protective Camera Window: Impact resistant polycarbonate lens with scratch resistant coating and water-tight gasket.

Condensation Drain Hole

DIP Switches (see page 7):
1: Normal Audio Detection
2: Increased Audio Detection

Speaker Volume

DIP Switches (see page 7):
1: Push Button Feature (connect / disconnect)
2: Auto Answer Feature (on/off)
3: Programming Switch (normal/programming)

Microphone: Omni-directional microphone with protective water-resistant cloth.

Speaker: Mylar speaker with rubber gasket to maintain water-tight seal and eliminate water deterioration.

Speaker Screen: Stainless steel speaker screen with 0.018" diameter holes to prevent punctures from paperclips, etc.

Push Button Switch: Push to initiate call, push again to disconnect. Solid 316 stainless steel internally sealed per IP67.

LED: Lights blue for "In-Use" indication.

Faceplate Gasket: 1/8" thick closed cell PVC to provide a water-tight seal.

Earth Ground: To increase surge protection, loosen the screw labeled ⊕ (as shown) and fasten a wire with ring terminal (included) from the mounting screw to Earth Ground (grounding rod, water pipe, etc.)

Installation

⚠ IMPORTANT: Electronic devices are susceptible to lightning and power station electrical surges from both the AC outlet and the telephone line. It is recommended that a surge protector be installed to protect against such surges.

Caution: When warm air comes in contact with cold surfaces, such as outside walls and conduits, it causes condensation. To prevent condensation from accumulating inside the E-35 always bring conduit into the bottom of the unit. If this is not possible, drill a 1/4" diameter hole in the bottom of the gray plastic box..

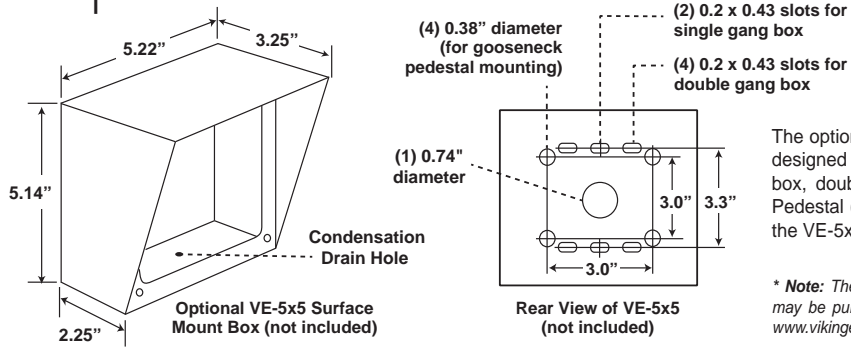
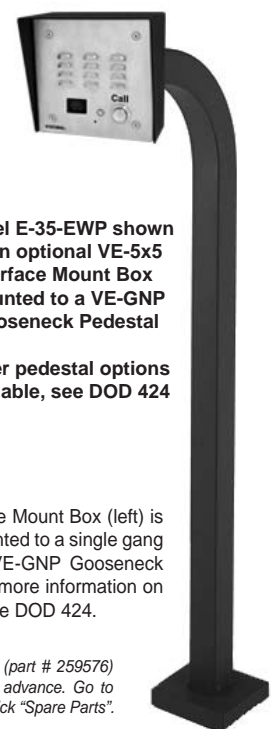
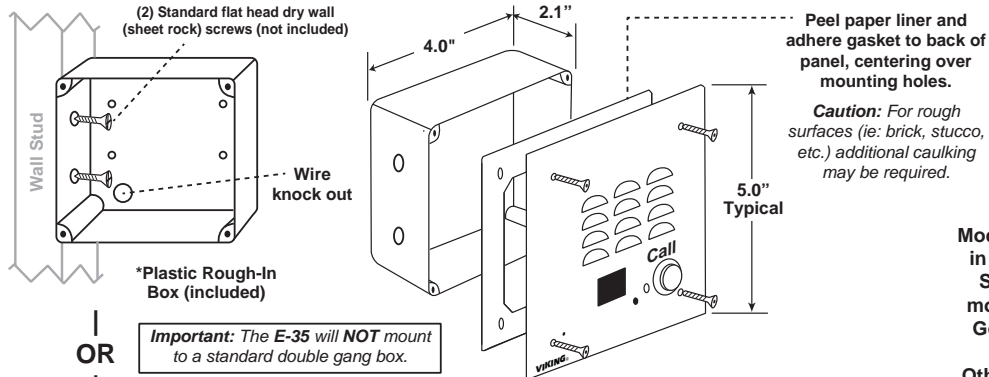

The optional VE-5x5 Surface Mount Box (left) is designed to be surface mounted to a single gang box, double gang box or VE-GNP Gooseneck Pedestal (shown right). For more information on the VE-5x5 and VE-GNP, see DOD 424.

* Note: The plastic rough-in box (part # 259576) may be purchased separately in advance. Go to www.vikingelectronics.com and click "Spare Parts".

Wiring

A. Wiring the E-35 Phone Board

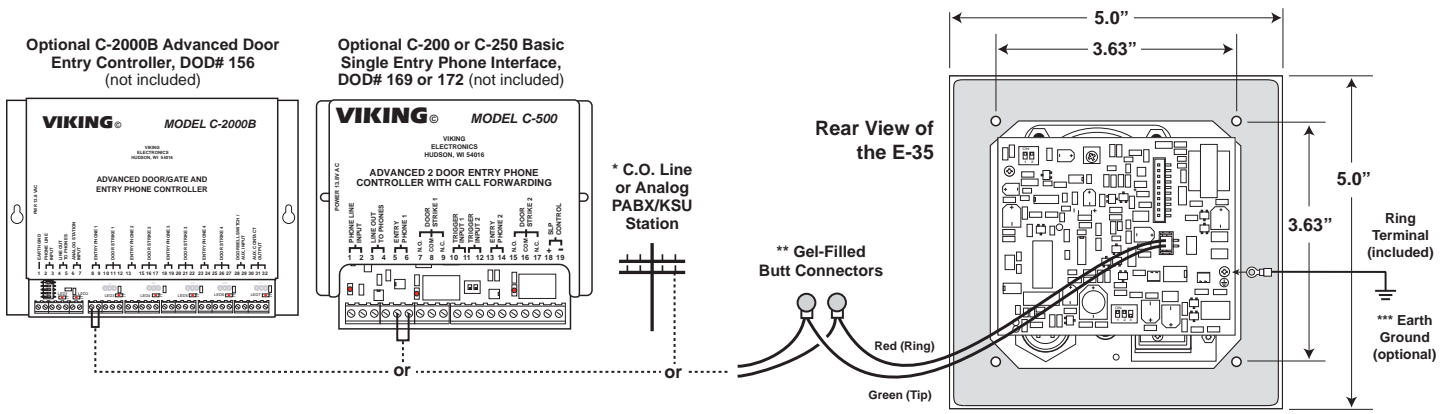

* Note: When installing a line powered phone on a low voltage and/or low loop current phone system extension, a **TBB-1B** Talk Battery Booster may be required, see **DOD# 632** for more information.

** Note: The gel-filled (water-tight) butt connectors are designed for insulation displacement on 19-26 gauge wire with a maximum insulation of 0.082 inches. Cut off bare wire ends prior to terminating.

*** Note: To increase surge protection, loosen the PCB mounting screw labeled \oplus (as shown above) and fasten a wire with spade terminal (included) from the mounting screw to Earth Ground (grounding rod, water pipe, etc.)

B. Wiring the E-35 Camera

1. Using RG59 for Video and CAT5 for Camera Power and Phone Board Audio (Recommended)

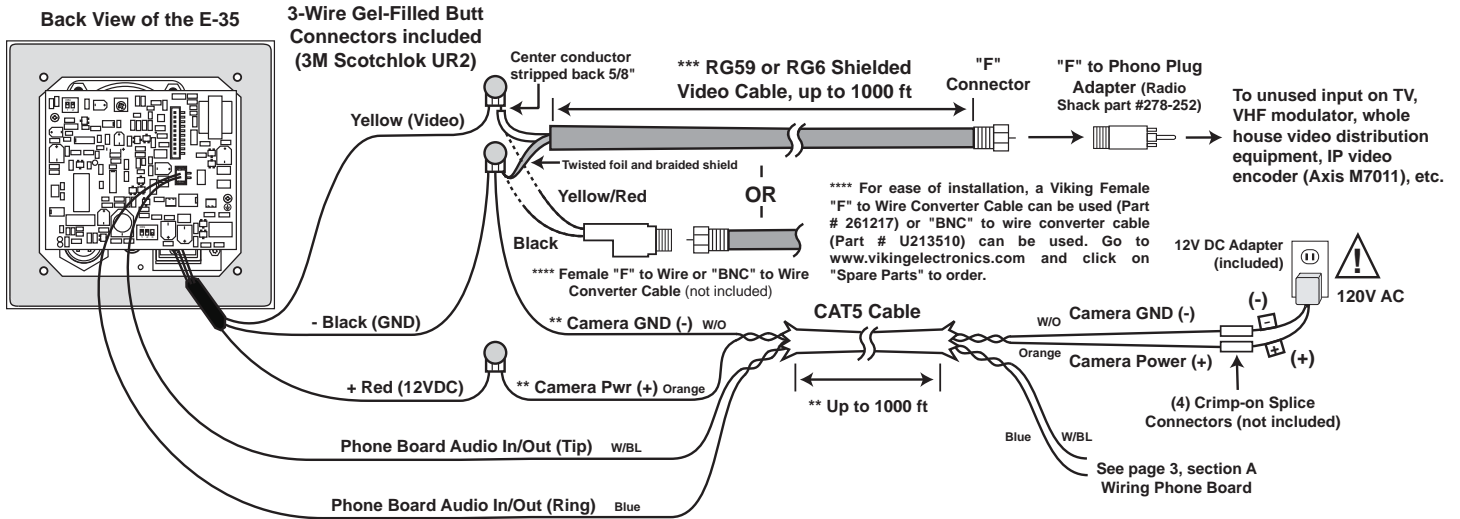

2. Using CAT5E or CAT6 for Video, Camera Power and Phone Board Audio (see Caution below)

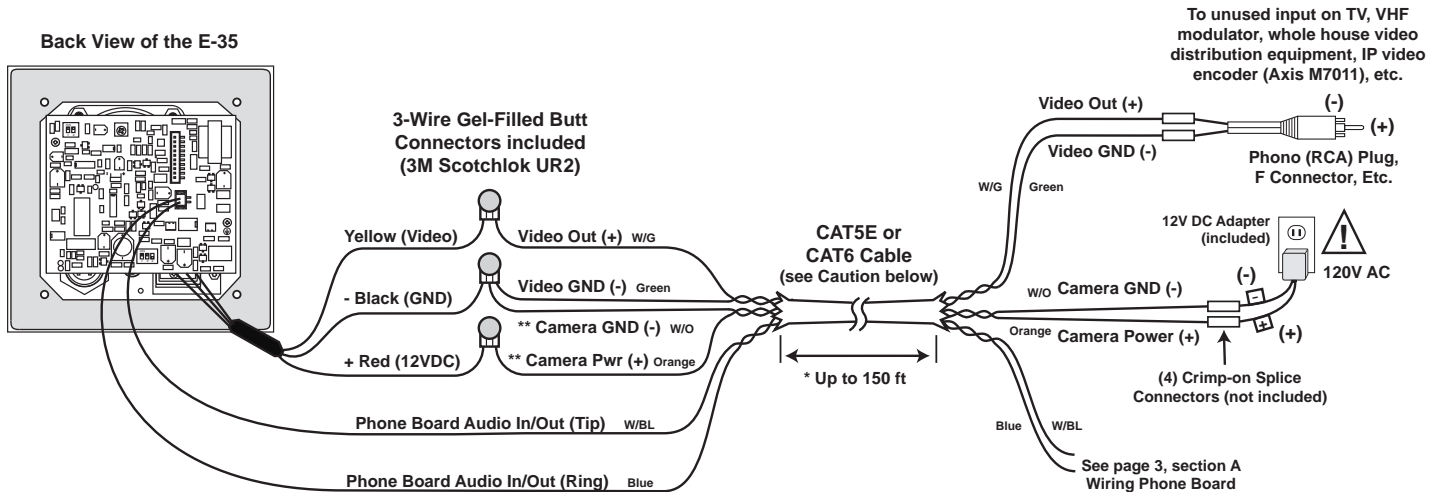

IMPORTANT: Electronic devices are susceptible to lightning and power station electrical surges from both the AC outlet and the telephone line. It is recommended that a surge protector be installed to protect against such surges.

* **Note:** Up to 150 ft video cable run length can be achieved using CAT5E or CAT6 cable. Longer cable runs can be used if a passive or active video Balun transceiver is used on each end of the cable. Generally, passive transceivers can achieve up to 750 ft cable runs where active transceivers can achieve up to 3000 ft runs depending on cable type, etc. The type of video balun transceiver required is specific to your cable run length. For more information on video balun transceivers go to: www.northernvideo.com.

** **Note:** The maximum camera power supply wire run length is 1000 ft of 24 gauge wire (CAT 5/6), longer runs are possible by doubling pairs, increasing the wire gauge or using up to a 22V DC 200mA power adapter.

*** **Note:** RG59 or RG6 with solid center conductor and 95% bare copper braid shield.

Caution: When routing CAT5E or CAT6 cable, maintain a minimum distance of 3 ft from any parallel high voltage wire (110 VAC) and a minimum of 2 ft from crossing any high voltage wire. For installations where RF noise is expected (commercial applications) or wire runs are near high voltage (110 VAC) wires, a shielded video cable such as RG6 is recommended.

C. Adjusting the Camera

The camera can be tilted and rotated to your desired position. A portable service (test) monitor can be used to determine the correct viewing angle during installation.

Important: To prevent the edge of the faceplate from being viewed in the video image, do not rotate the camera beyond 30 degrees or tilt beyond 20 degrees.

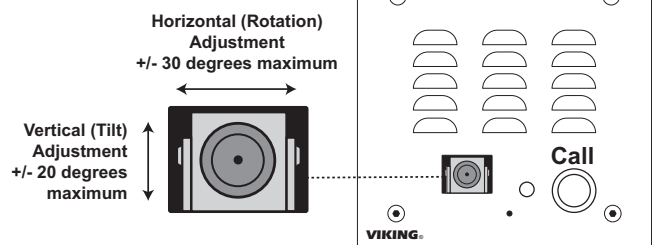

Programming

A. Accessing the Programming Mode

The **E-35** phone can be programmed from any Touch Tone phone using a C.O. line, analog PABX/KSU station, or a **DLE-200B** Line Simulator. For more information on the **DLE-200B**, see **DOD 605**.

1. Using the Security Code

Step 1.	Move DIP switch 2 to the ON position (sets unit to answer incoming calls, see section H).
Step 2.	From a Touch Tone phone call the line attached to the E-35 phone.
Step 3.	When the E-35 phone answers, enter the 6-digit security code (factory set to 845464 , see section B). A double beep should then be heard indicating you have entered the programming mode.

2. Without the Security Code

Step 1.	Move DIP switch 2 to the ON position (sets unit to answer incoming calls, see section H).
Step 2.	Move DIP switch 3 to the OFF position (incoming calls enter Programming without security code, see section H).
Step 3.	From a Touch Tone phone call the line attached to the E-35 .
Step 4.	When the E-35 answers, a double beep will be heard and will automatically enter the programming mode.
Step 5.	When finished programming, move DIP switch 3 back to the ON position (see section H).

Warning: Failure to do step 5 above will cause the **E-35** phone to call Viking Technical Support instead of your programmed number. See Section **G**, Assisted Programming. **Note:** If a valid memory position is entered, a double beep will be heard. Four beeps indicate an error.

B. Security Code (memory location #19)

The security code allows the user/installer to program the **E-35** phone while DIP switch **3** is in the **ON** (normal) position. The factory set security code is 845464 (V-I-K-I-N-G). It is recommended that the factory set security code be changed.

Example: To store 123456 as the security code:

Step 1.	Access programming as shown in Programming section A above.
Step 2.	Enter 123456 #19 .
Step 3.	Hang-up.

Enter Your Security Code Here:

						#19
--	--	--	--	--	--	------------

Note: The security code must be 6 digits and cannot include a * or a #.

C. Quick Programming Features

Description	Enter Digits	+	Memory Location
First speed dial number	0-20 digits	then	#00
Second speed dial number	0-20 digits	then	#01
Third speed dial number	0-20 digits	then	#02
Fourth speed dial number	0-20 digits	then	#03
Fifth speed dial number	0-20 digits	then	#04
To add a * at any point in the dialing string	**		
To add a # at any point in the dialing string	*#		
To add a four second pause at any point in the dialing string	*7		
Miscellaneous options (factory set to 001210)	6 digits	then	#17
Timing/Dialing options (factory set to 234721)	6 digits	then	#18
Security code (factory set to 845464)	6 digits	then	#19
Exit programming and disconnect	#7		
Reset all programming to factory default settings	###		

D. Speed Dial Numbers (Memory Locations #00 - #04)

Note: Up to 20 digits can be stored in each dial position. Special features such as pause, mode change, touch tone * and # count as single digits.

The speed dial number programmed in location **#00** is the telephone or extension number that is dialed when the "Call" button is first pressed. Additional speed dial numbers will be dialed when there is no answer or a busy signal is detected and the next number redial features are activated. The **E-35** will cycle through the programmed speed dial numbers until answered. To program, enter the desired speed dial number followed by the memory location number (**#00 - #04**).

To clear a speed dial location, simply enter the memory location (**#00 - #04**) alone. The **E-35** is factory set with no speed dial number programmed.

To Program:	Enter:
*	**
#	*#
4 second pause	*7
0, 1, 2 9	0, 1, 2 9

E. Timing/Dialing Options (memory location #18)

There are six positions in the timing/dialing options. To program these options, enter the six desired timing/dialing numbers followed by #18. The six available timing/dialing options are defined as follows:

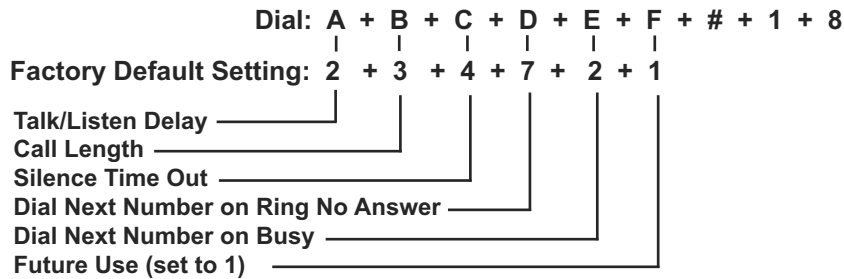

Enter Timing/Dialing Settings Here:

A	B	C	D	E	F	

#18

Setting A - Talk/Listen Delay

This feature selects switching time between talk and listen modes (VOX switching time). Use chart at the right. * **Note:** The factory default is .2 seconds.

Touch Tone	Talk/Listen Delay
1	0.1 seconds
2	0.2 seconds*
3	0.3 seconds
4	0.4 seconds
5	0.5 seconds
6	0.6 seconds
7	0.7 seconds
8	0.8 seconds
9	0.9 seconds

Setting B - Call Length Time Out

This feature selects the maximum length of time that calls can be connected. Programmable in increments of 1 minute up to a maximum of 9 minutes (Touch Tones 1 - 9). Program 0 in this location to disable the call length time out. With the call length disabled, the E-35 phone must rely on a CPC signal, busy signal, silence or return to dial tone to hang-up. Use chart at the right.

* **Note:** The factory default is 3 minutes.

Touch Tone	Call Length Time Out
0	Disabled
1	1 minute
2	2 minutes
3	3 minutes*
4	4 minutes
5	5 minutes
6	6 minutes
7	7 minutes
8	8 minutes
9	9 minutes

Setting C - Silence Time Out

This feature selects the length of time that calls will remain connected without voice activity. Programmable in increments of 10 seconds up to a maximum of 90 seconds (Touch Tones 1 - 9). To disable the silence time out, program 0 in this location. Use chart at the far right. * **Note:** The factory default is 40 seconds.

Touch Tone	Silence Time Out
0	Disabled
1	10 seconds
2	20 seconds
3	30 seconds
4	40 seconds*
5	50 seconds
6	60 seconds
7	70 seconds
8	80 seconds
9	90 seconds

Setting D - Dial Next Number on Ring No Answer

If enabled and a ring-no-answer is detected, the E-35 phone will dial the next programmed speed dial number, and continue to cycle through the speed dial numbers until a call is completed.

* **Note:** Factory set to redial if not answered after 7 rings.

Touch Tone	Setting D
1 or 0	Disabled*
2, 3, 4...9	Dials second number after 2, 3, 4...9 rings respectively

Setting E - Dial Next Number on Busy

If enabled and a busy is detected, the E-35 phone will dial the next programmed speed dial number, and continue to cycle through the numbers until a call is completed. * **Notes:** This feature is enabled in the factory default setting. If the busy signal is interrupted with a promotional message, contact your central office to have it removed.

Touch Tone	Setting E
1	Disabled
2	Enabled*

Setting F - Future Use (set to 1)

F. Miscellaneous Options (memory location #17)

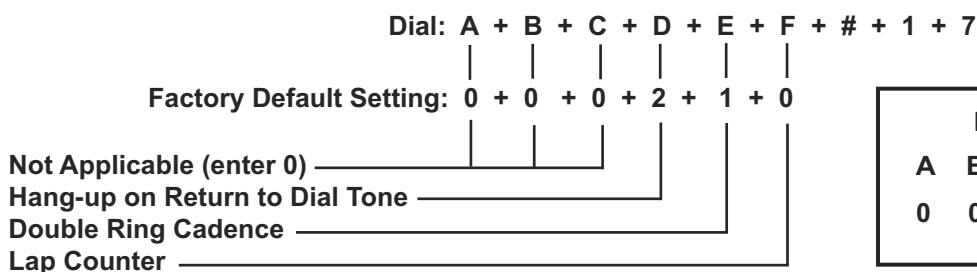

Enter Settings Here:

A	B	C	D	E	F	
0	0	0				

#17

Settings A / B / C - Not Applicable

Setting D - Hang Up on Return to Dial Tone

If enabled and a return dial tone is detected, the **E-35** will hang up.

* **Note:** The factory default setting is enabled.

Touch Tone	Setting D
1	Disabled
2	Enabled*

Setting E - Double Ring Cadence Mode

The **E-35** can be programmed to recognize the double ring cadence that is typical of many phone systems. If the **E-35** is connected to an extension that provides a double ring cadence, enabling this mode will allow for proper call progress detection.

* **Note:** This feature is disabled in the factory default setting.

Touch Tone	Setting E
1	Disabled*
2	Enabled

Setting F - Lap Counter

With the lap counter disabled (factory setting), if the **E-35** is programmed to dial the next number on ring-no-answer and/or busy signal (see page 6), the **E-35** will continuously call its programmed phone numbers forever until the call is answered.

The lap counter is a programmable counter that determines how many times the **E-35** will cycle through its list of up to 5 emergency numbers (or up to 3 "Info" phone numbers), before it stops the dialing process and hangs up. When all of the programmed phone numbers have been dialed, the lap counter is incremented and the dialing process repeats. When the lap counter has been met, the dialing process stops and the **E-35** hangs up. * **Note:** This feature is disabled in the factory default setting.

Touch Tone	Setting F
0	Disabled*
1-9	Lap count: 1-9 times

G. Assisted Programming

When attempting to program the **E-35** phone, if the phone number of the line it is connected to is not known, the phone can be set to automatically call Viking technical support for assistance. With DIP switch 3 set to OFF (programming mode), pushing the CALL button will cause the **E-35** phone to call Viking, whether it be connected directly to a CO line, or behind a "dial 9" PBX.

The **E-35** phone will first dial 9, and then listen for second dial tone; if detected it will continue to dial Viking's assisted programming phone number. If a second dial tone is not detected, it then knows it is not behind a PBX, so it will momentarily hang up and then directly dial Viking's assisted programming phone number. Since this is a long distance phone call, the line must be capable of placing long distance calls for the call to go through. When finished programming, it is very important to set DIP switch 3 back to ON (normal operating mode), and place a test emergency call to be sure all programming was done properly.

Warning: Failure to set DIP switch 3 back to ON when finished programming will cause the E-35 phone to call Viking Technical Support, instead of your programmed speed dial number. Yet, as a fail-safe measure, after 3 calls to Viking, the unit will ignore switch 3 and dial its programmed phone numbers.

H. DIP Switch Programming/Speaker and Microphone Adjustments

A speaker volume POT is provided to increase or decrease the speakerphone volume. **Note:** The Microphone Sensitivity POT has been removed because the microphone sensitivity is now microprocessor controlled. This allows the mic gain to be automatically increased in a quiet environment, allowing the distant party to clearly hear even soft or distant sounds. The microprocessor will automatically reduce the mic sensitivity when the location becomes noisy. This Automatic Noise Canceling (ANC) feature will allow speakerphone two-way communications to continue to work properly, even when subjected to loud noise such as a diesel engine or traffic.

Switch A	Switch B	Description
ON	ON	Normal audio detection
OFF	OFF	Increase audio detect sensitivity for low level lines. Useful in applications in which voice or busy signals have trouble breaking over the speaker.

Switch	Position	Description
1	ON	"CALL" button alternately connects/disconnects calls (factory default)
1	OFF	"CALL" button connects calls only
2	ON	Incoming calls answered (factory setting)
2	OFF	Incoming calls are not answered
3	ON	Normal operation mode (factory setting)
3	OFF	Learn mode - Any incoming calls are automatically entered into the programming mode (no security code required). Use this option if you have forgotten your security code. Any outbound call will dial Viking Technical Support (see section I). Warning: When finished programming, set this switch back to the ON position, otherwise the E-35 phone will only call Viking Technical Support instead of your programmed emergency number.

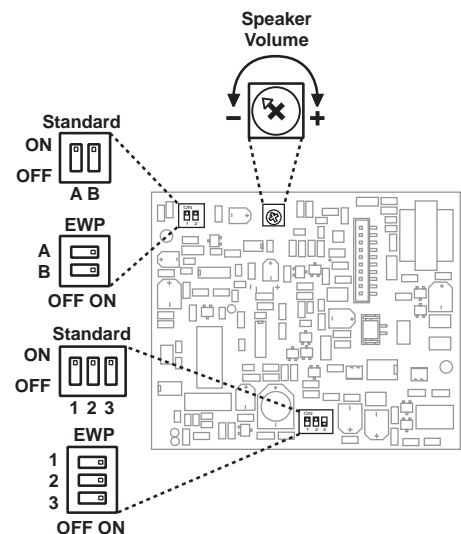

I. Programming Examples

To Program the E-35 Phone...	Step 1	Step 2
...to store 123456 as the security code	Access Programming (see page 5)	Enter digits: 1 2 3 4 5 6 # 1 9
...to store 555-1234 in the second speed dial position	Access Programming (see page 5)	Enter digits: 5 5 5 1 2 3 4 # 0 1
...to store a touch tone 9, a four second pause, and then a pulse dialed 333-4444 into the first speed dial position	Access Programming (see page 5)	Enter digits: 9 *7 *6 3 3 3 4 4 4 4 # 0 0

Operation

When the "Call" button is pressed, the E-35 phone goes off-hook, and dials a pre-programmed telephone number. The front panel LED will light any time the phone is off hook, and flash to show dialing. In the event that the line is busy or there is a ring-no answer, the unit can be programmed to call additional phone numbers. The phone then cycles through up to 5 pre-programmed speed dial numbers until the call is answered. The E-35 will hang up on CPC, silence, busy signal, return to dial tone, time out or Touch Tone command (*#). If programmed to auto-answer, the E-33 will also answer any incoming call. The E-35 color video camera operates completely independently of the E-35 phone board. With power supplied to the camera, it will continuously output a video signal.

Warranty

IF YOU HAVE A PROBLEM WITH A VIKING PRODUCT, PLEASE CONTACT: VIKING TECHNICAL SUPPORT AT 715-386-8666

Our Technical Support Department is available for assistance Monday 8am - 4pm and Tuesday through Friday 8am - 5pm central time. So that we can give you better service, before you call please:

1. Know the model number, the serial number and what software version you have (see serial label).
2. Have your Product Manual in front of you.
3. It is best if you are on site.

RETURNING PRODUCT FOR REPAIR

The following procedure is for equipment that needs repair:

1. Customer must contact Viking's Technical Support Department at 715-386-8666 to obtain a Return Authorization (RA) number. The customer MUST have a complete description of the problem, with all pertinent information regarding the defect, such as options set, conditions, symptoms, methods to duplicate problem, frequency of failure, etc.
2. Packing: Return equipment in original box or in proper packing so that damage will not occur while in transit. Static sensitive equipment such as a circuit board should be in an anti-static bag, sandwiched between foam and individually boxed. All equipment should be wrapped to avoid packing material lodging in or sticking to the equipment. Include ALL parts of the equipment. C.O.D. or freight collect shipments cannot be accepted. Ship cartons prepaid to:
Viking Electronics, 1531 Industrial Street, Hudson, WI 54016
3. Return shipping address: Be sure to include your return shipping address inside the box. We cannot ship to a PO Box.
4. RA number on carton: In large printing, write the R.A. number on the outside of each carton being returned.

RETURNING PRODUCT FOR EXCHANGE

The following procedure is for equipment that has failed out-of-box (within 10 days of purchase):

1. Customer must contact Viking's Technical Support at 715-386-8666 to determine possible causes for the problem. The customer MUST be able to step through recommended tests for diagnosis.
2. If the Technical Support Product Specialist determines that the equipment is defective based on the customer's input and troubleshooting, a Return Authorization (R.A.) number will be issued. This number is valid for fourteen (14) calendar days from the date of issue.
3. After obtaining the R.A. number, return the approved equipment to your distributor, referencing the R.A. number. Your distributor will then replace the product over the counter at no charge. The distributor will then return the product to Viking using the same R.A. number.
4. **The distributor will NOT exchange this product without first obtaining the R.A. number from you. If you haven't followed the steps listed in 1, 2 and 3, be aware that you will have to pay a restocking charge.**

TWO YEAR LIMITED WARRANTY

Viking warrants its products to be free from defects in the workmanship or materials, under normal use and service, for a period of two years from the date of purchase from any authorized Viking distributor. If at any time during the warranty period, the product is deemed defective or malfunctions, return the product to Viking Electronics, Inc., 1531 Industrial Street, Hudson, WI., 54016. Customer must contact Viking's Technical Support Department at 715-386-8666 to obtain a Return Authorization (R.A.) number.

This warranty does not cover any damage to the product due to lightning, over voltage, under voltage, accident, misuse, abuse, negligence or any damage caused by use of the product by the purchaser or others. This warranty does not cover non-EWP products that have been exposed to wet or corrosive environments. This warranty does not cover stainless steel surfaces that have not been properly maintained.

NO OTHER WARRANTIES. VIKING MAKES NO WARRANTIES RELATING TO ITS PRODUCTS OTHER THAN AS DESCRIBED ABOVE AND DISCLAIMS ANY EXPRESS OR IMPLIED WARRANTIES OR MERCHANTABILITY OR FITNESS FOR ANY PARTICULAR PURPOSE.

EXCLUSION OF CONSEQUENTIAL DAMAGES. VIKING SHALL NOT, UNDER ANY CIRCUMSTANCES, BE LIABLE TO PURCHASER, OR ANY OTHER PARTY, FOR CONSEQUENTIAL, INCIDENTAL, SPECIAL OR EXEMPLARY DAMAGES ARISING OUT OF OR RELATED TO THE SALE OR USE OF THE PRODUCT SOLD HEREUNDER.

EXCLUSIVE REMEDY AND LIMITATION OF LIABILITY. WHETHER IN AN ACTION BASED ON CONTRACT, TORT (INCLUDING NEGLIGENCE OR STRICT LIABILITY) OR ANY OTHER LEGAL THEORY, ANY LIABILITY OF VIKING SHALL BE LIMITED TO REPAIR OR REPLACEMENT OF THE PRODUCT, OR AT VIKING'S OPTION, REFUND OF THE PURCHASE PRICE AS THE EXCLUSIVE REMEDY AND ANY LIABILITY OF VIKING SHALL BE SO LIMITED.

IT IS EXPRESSLY UNDERSTOOD AND AGREED THAT EACH AND EVERY PROVISION OF THIS AGREEMENT WHICH PROVIDES FOR DISCLAIMER OF WARRANTIES, EXCLUSION OF CONSEQUENTIAL DAMAGES, AND EXCLUSIVE REMEDY AND LIMITATION OF LIABILITY, ARE SEVERABLE FROM ANY OTHER PROVISION AND EACH PROVISION IS A SEPARABLE AND INDEPENDENT ELEMENT OF RISK ALLOCATION AND IS INTENDED TO BE ENFORCED AS SUCH.

FCC REQUIREMENTS

This equipment complies with Part 68 of the FCC rules and the requirements adopted by the ACTA. Inside the front panel of this equipment is a label that contains, among other information, a product identifier in the format US:AAAEQ##TXXXX. If requested, this number must be provided to the telephone company.

The REN is used to determine the number of devices that may be connected to a telephone line. Excessive REN's on a telephone line may result in the devices not ringing in response to an incoming call. In most but not all areas, the sum of the REN's should not exceed five (5.0). To be certain of the number of devices that may be connected to a line, as determined by the total REN's, contact the local telephone company. For products approved after July 23, 2001, the REN for this product is part of the product identifier that has the format US:AAAEQ##TXXXX. The digits represented by ## are the REN without a decimal point (e.g., 03 is a REN of 0.3). For earlier products, the REN is separately shown on the label.

The plug used to connect this equipment to the premises wiring and telephone network must comply with the applicable FCC Part 68 rules and requirements adopted by the ACTA. If your home has specially wired alarm equipment connected to the telephone line, ensure the installation of this E-35 does not disable your alarm equipment. If you have questions about what will disable alarm equipment, consult your telephone company or a qualified installer.

If the E-35 causes harm to the telephone network, the telephone company will notify you in advance that temporary discontinuance of service may be required. But if advance notice isn't practical, the telephone company will notify the customer as soon as possible. Also, you will be advised of your right to file a complaint with the FCC if you believe it is necessary.

The telephone company may make changes in its facilities, equipment, operations, or procedures that could affect the operation of the equipment. If this happens, the telephone company will provide advance notice in order for you to make

the necessary modifications to maintain uninterrupted service.

If trouble is experienced with the E-35, for repair or warranty information, please contact:

Viking Electronics, Inc., 1531 Industrial Street, Hudson, WI 54016 715-386-8666

If the equipment is causing harm to the telephone network, the telephone company may request that you disconnect the equipment until the problem is resolved.

Connection to Party Line Service is subject to State Tariffs. Contact the state public utility commission, public service commission or corporation commission for information.

WHEN PROGRAMMING EMERGENCY NUMBERS AND (OR) MAKING TEST CALLS TO EMERGENCY NUMBERS:

Remain on the line and briefly explain to the dispatcher the reason for the call. Perform such activities in the off-peak hours, such as early morning or late evenings.

It is recommended that the customer install an AC surge arrester in the AC outlet to which this device is connected. This is to avoid damaging the equipment caused by local lightning strikes and other electrical surges.

PART 15 LIMITATIONS

This equipment has been tested and found to comply with the limits for a Class A digital device, pursuant to Part 15 of the FCC Rules. These limits are designed to provide reasonable protection against harmful interference when the equipment is operated in a commercial environment. This equipment generates, uses, and can radiate radio frequency energy and, if not installed and used in accordance with the instruction manual, may cause harmful interference to radio communications. Operation of this equipment in a residential area is likely to cause harmful interference in which case the user will be required to correct the interference at his own expense.

Product Support: 715-386-8666

Due to the dynamic nature of the product design, the information contained in this document is subject to change without notice. Viking Electronics, and its affiliates and/or subsidiaries assume no responsibility for errors and omissions contained in this information. Revisions of this document or new editions of it may be issued to incorporate such changes.