



# TECHNICAL Practice

**TELECOM SOLUTIONS FOR THE 21ST CENTURY**

**ZPI-4**  
**Four Zone**  
**Paging Interface**

July 11, 2000

## Four Zone Paging Interface

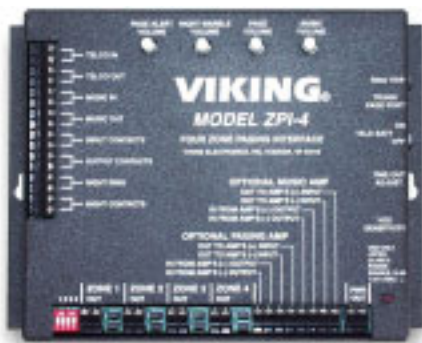

The **ZPI-4** is a four-zone Touch Tone controlled paging system capable of switching a line level signal (600 ohms) to amplifiers, 70V signal to speakers or an amplified signal (200 watts maximum into 8 ohms) to speakers.

The **ZPI-4** features balanced audio circuitry throughout for low noise and compatibility with balanced paging system inputs and outputs. There are separate level controls for paging and background music, and background music can be disabled on a per-zone basis. Also provided is a night bell with adjustable volume activated by a dry contact closure, a ringing C.O. or a ringing analog PABX/KSU station.

The **ZPI-4** is compatible with ringing C.O. lines, Centrex lines and analog PABX/KSU station ports (disconnects on silence, CPC, busy or time-out) as well as unused trunk inputs, and will interface directly with standard paging ports.

### Features

- Touch Tone control of four zones, expandable to 8 zones
- Switches line level signal to amplifiers or amplified signal to speakers (amplifier(s) not included)
- Balanced audio circuitry for low noise
- Night bell warble with adjustable level from contact closure or ringing analog line
- Input provided for background music
- Separate paging and background music level adjustments
- Background music automatically mutes in paged zone(s) in all but single amplifier mode
- All-call and five group call patterns, selected by Touch Tones
- Adjustable page alert tone level
- Interfaces with ringing C.O. lines, Centrex lines, and analog station ports, paging ports and unused phone system trunk ports
- Disconnects on silence, CPC, busy or time-out
- Screw terminals for all input/output connections
- Compatible with Viking's **FBI-1A** Anti-Feedback Paging Interface (**Fax Back Document 465**)

### Applications

- Multiple zone paging for Centrex systems
- Multiple zone paging for phone systems with paging ports, unused analog station ports or unused trunk inputs
- Multiple department manufacturing business
- Multilevel warehouse
- Multi building office complex

**Phone... 715.386.8861**

**[info@vikingelectronics.com](mailto:info@vikingelectronics.com)**

**<http://www.vikingelectronics.com>**

### Specifications

**Power:** 120V AC/13.8V AC, 1.25A adapter provided  
**Dimensions:** 210mm x 159mm x 45mm (8.25" x 6.25" x 1.75")  
**Shipping Weight:** 1.5 kg (3.2 lbs)  
**Environmental:** 0° C to 32° C (32° F to 90° F) with 5% to 95% non-condensing humidity  
**Relay Contacts:** 5 Amps@30V DC/250V AC each (200w@8Ω)  
**REN:** 0.5 A  
**Artificial Talk Battery Voltage:** 24V DC  
**Connections:** (34) cage clamp screw terminals

# Installation

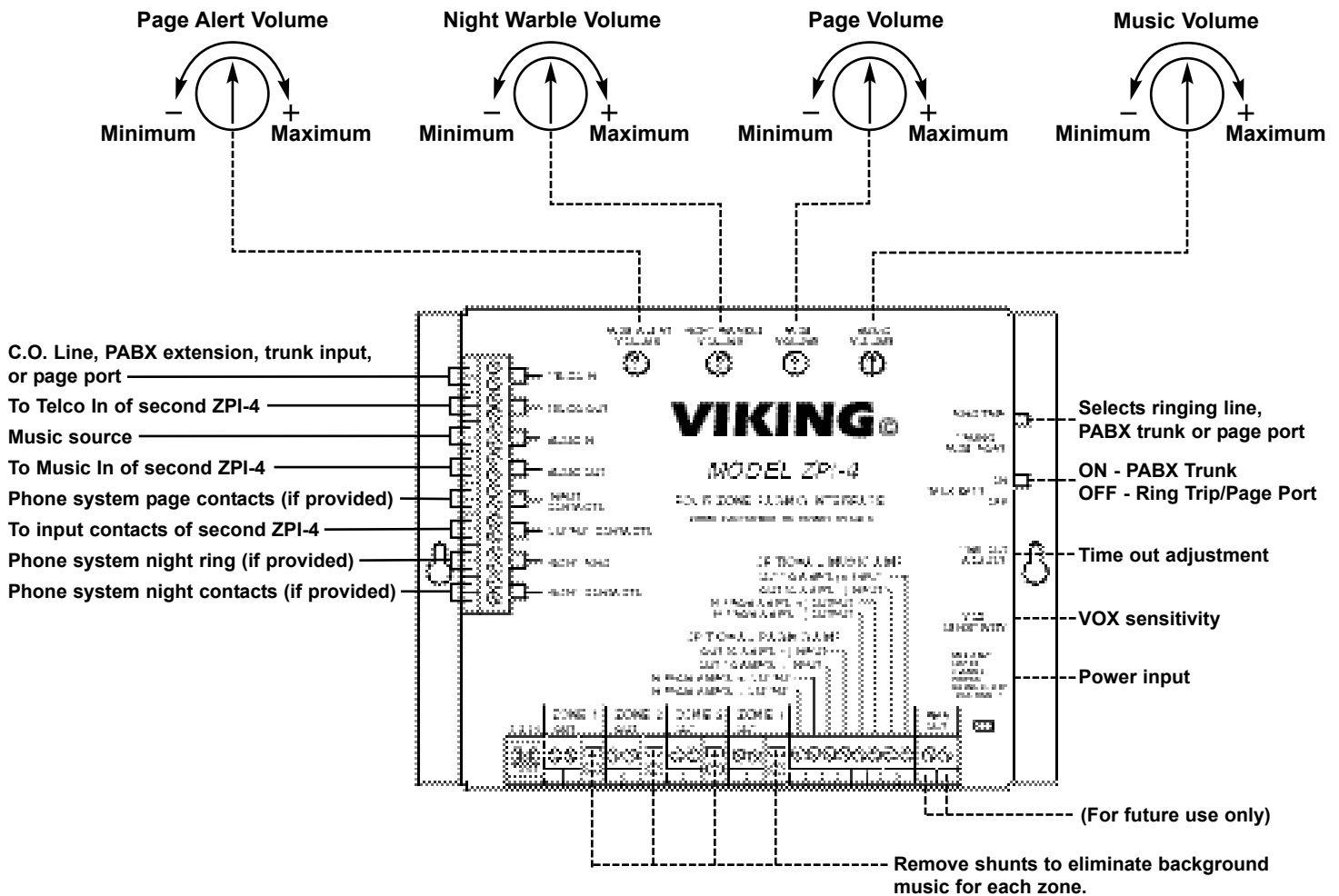

## A. Four Amplifier Mode

In this mode, each paging zone has its own amplifier, and the function of the ZPI-4 is to switch the unamplified paging or background music signal to the appropriate amplifier.

**Advantages:** There is no amplifier power limitation, zones can be set to different volumes, background music is selectable per zone and the non-paged zones will continue to get music during a page.

To set the ZPI-4 up in the four amplifier mode:

1. Hook up the ZONE 1 screw terminals to the input of the amplifier for Zone 1.
2. If background music is to be enabled on this zone, ensure that the ZONE 1 music shunts are in place, covering both pins. If not, remove the shunts.
3. Repeat steps 1 and 2 for each of the remaining three zones.
4. Install two of the included jumpers on the Optional Paging Amp screw terminals.
5. If a background music source is being used, install the remaining two jumpers on the Optional Music Amp screw terminals.
6. Set DIP switch 1 to OFF.

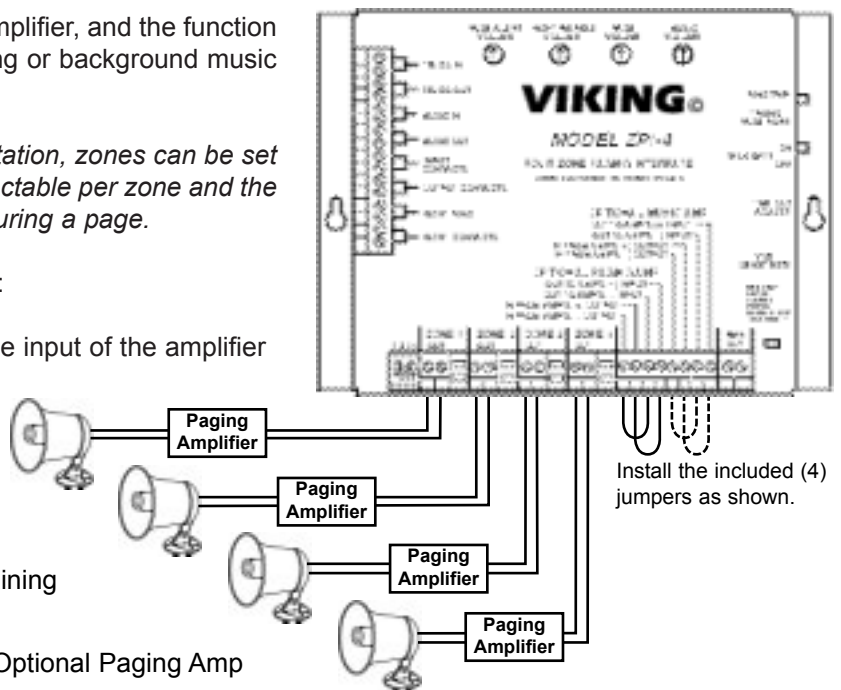

## B. Two Amplifier Mode

In the two amplifier mode, one amp serves as the paging amplifier and the other as the background music amplifier. The paging or music signal is sent to the external amplifier, returned and the amplified signal is switched by the **ZPI-4** to the correct zone or zones.

**Advantages:** Any size amplifier may be used when driving 70V speakers, only (2) amplifiers (or one stereo amp) are required for 4 zones, background music is selectable per zone, and the non-paged zones will continue to get music during a page.

**Limitations:** The paging amp needs to be limited to 200 watts and the music amp needs to be limited to 70 watts when switching 8 ohm speaker loads, each speaker zone is limited to 8 ohms minimum impedance and the amp must have the ability to drive the speakers of all zones. (Example: 4 zones at 8 ohms per zone equals a 2 ohm load during an all call.)

To set up the **ZPI-4** in the two amplifier mode:

1. Hook up the ZONE 1 screw terminals to the speaker(s) for Zone 1.
2. If background music is to be enabled on this zone, ensure that the ZONE 1 music shunts are in place, covering both pins. If not, remove the shunts.
3. Repeat steps 1 and 2 for each remaining zone.
4. Hook up the optional paging amp and the optional music amp as shown.
5. Set DIP switch 1 to OFF.

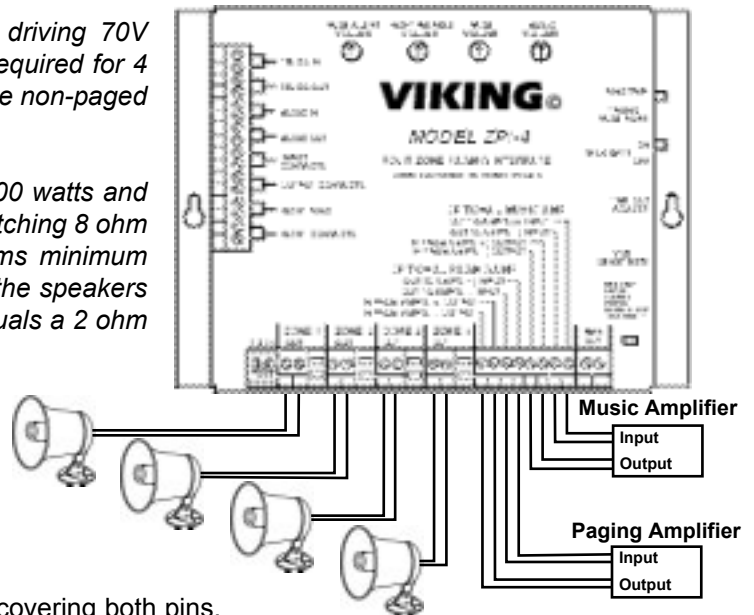

## C. Single Amplifier Mode

In this mode, one external amplifier handles both paging and background music. An internal relay capable of switching between paging signal and music signal sends input to this amp, the amplified signal is returned and the **ZPI-4** sends it to the correct zone(s).

**Advantages:** Any size amplifier may be used when driving 70V speakers, only one amplifier is required.

**Limitations:** The amplifier needs to be limited to 200 watts, each speaker zone is limited to an 8 ohm minimum impedance, the amplifier must be able to drive the speakers of all zones (Example: 4 zones at 8 ohms per zone equals a 2 ohm load during an all call); if background music is used, all zones will receive background music and it will be muted in all zones during a page.

To set up the **ZPI-4** in the single amplifier mode:

1. Turn Dip switch 1 on. This tells the **ZPI-4** that it is operating in the single amplifier mode.
2. Hook up the ZONE 1 screw terminals to the speaker(s) for Zone 1.
3. Repeat step 2 for each of the remaining three zones.
4. Hook up the optional paging amp as shown.

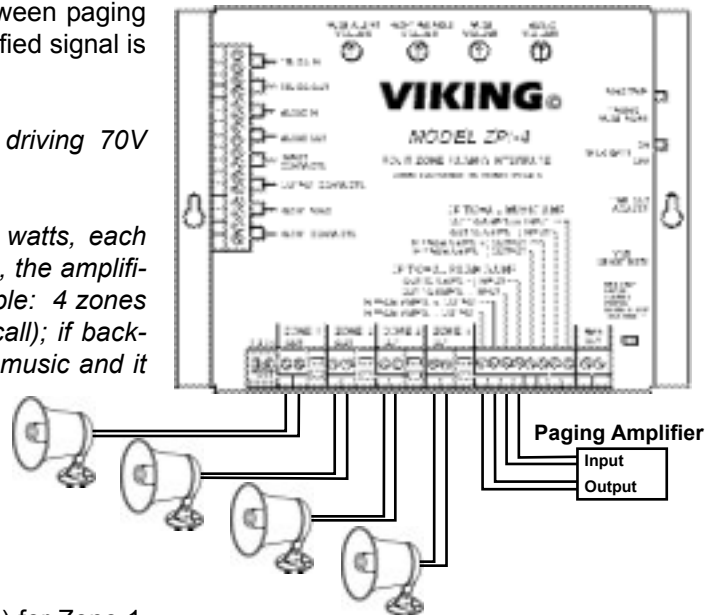

# Programming

Switch	ON/OFF	Description
1	ON	Single amplifier
	OFF	Two or more amplifiers
2	ON	Two units
	OFF	Single unit
3	ON	Slave unit
	OFF	Master unit
4	ON	Dial tone enabled
	OFF	Dial tone disabled

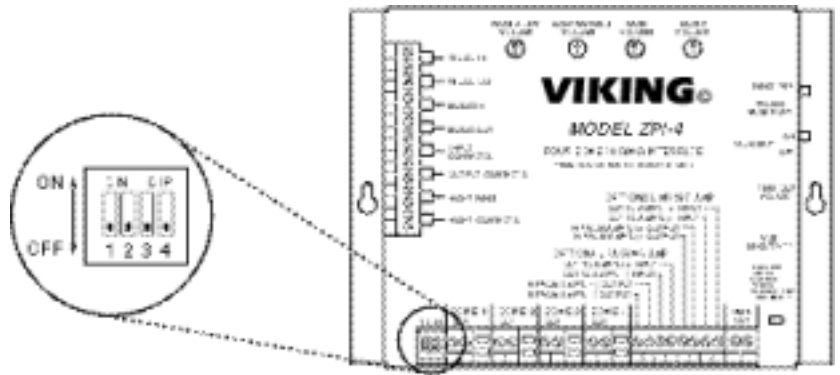

**Note:** DIP switches should be set prior to powering up the **ZPI-4**. If power has already been applied, momentarily power down the unit so the switches will take effect.

## A. Phone System Interface

### 1. Ring Trip Paging

- Set the **RING TRIP/TRUNK/PAGE PORT** switch to the **RING TRIP** position.
- Set the **TALK BATT** switch to the **OFF** position.
- Hook up **TIP** and **RING** to the **TELCO IN** screw terminals.
- Hook up the background music source, if used, to the **MUSIC IN** screw terminals.
- Adjust the **TIME OUT ADJUST** as required (adjustable from approximately 5 seconds to 80 seconds). This should be set to a second or two longer than the longest expected page. The **ZPI-4** hangs up when this timer is up, and if the timer is set for too short a time, the **ZPI-4** will hang up in the middle of a page.
- The **VOX SENSITIVITY** probably will not have to be adjusted unless the **ZPI-4** is disconnecting in the middle of pages and this is happening before the time set by the **TIME OUT ADJUST** or there is a period of silence during a page longer than three seconds and the **ZPI-4** does not auto-disconnect. To adjust the **VOX SENSITIVITY**, turn the pot counter clockwise to decrease the vox sensitivity and clockwise to increase it. The **VOX SENSITIVITY** should be decreased if the **ZPI-4** is auto-disconnecting in the middle of pages, and increased if it is not auto-disconnecting on periods of silence longer than three seconds.
- If the phone system provides a contact closure for night ring, connect a pair of wires from this closure to the **NIGHT CONTACTS** screw terminals. If the phone system provides ring signal for night ring, hook up a pair of wires from the phone system night ring output to the **NIGHT RING** screw terminals.
- Select dial tone if desired by putting DIP switch **4** to **ON**, otherwise turn it **OFF**.

### 2. Paging from an Unused Phone System Trunk Input

**Note:** In this mode, the **ZPI-4**'s time out and VOX sensitivity are disabled. The **ZPI-4** will release the trunk as soon as the paging party hangs up.

- Set the **RING TRIP/TRUNK/PAGE PORT** switch to the **TRUNK/PAGE PORT** position.
- Set the **TALK BATT** switch to the **ON** position.
- Hook up **TIP** and **RING** to the **TELCO IN** screw terminals.
- Hook up the background music source, if used, to the **MUSIC IN** screw terminals.
- If the phone system provides a contact closure for night ring, connect a pair of wires from this closure to the **NIGHT CONTACTS** screw terminals. If the phone system provides ring signal for night ring, hook up a pair of wires from the phone system night ring output to the **NIGHT RING** screw terminals.
- Select dial tone if desired by putting DIP switch **4** to **ON**, otherwise turn it **OFF**.

### 3. Paging from a Phone System's 600 Ohm Paging Port

*Note:* You must be able to send Touch Tones through the PABX's paging port for this mode to work.

- a. Set the **RING TRIP/TRUNK/PAGE PORT** switch to the **TRUNK/PAGE PORT** position.
- b. Set the **TALK BATT** switch to the **OFF** position.
- c. Hook up a pair of wires from the paging port to the **TELCO IN** screw terminals.
- d. Hook up the background music source, if used, to the **MUSIC IN** screw terminals.
- e. If the phone system provides a page dry contact closure, connect a pair of wires from this closure to the **INPUT CONTACTS** screw terminals. In this application, the **ZPI-4**'s time out and VOX sensitivity are disabled. The **ZPI-4** will release the page port as soon as its **INPUT CONTACTS** open.
- f. If the phone system does not provide a page dry contact closure, adjust the **TIME OUT ADJUST** as required (adjustable from approximately 5 seconds to 80 seconds). This should be set to a second or two longer than the longest expected page. The **ZPI-4** hangs up when this timer is up, and if the timer is set for too short a time, the **ZPI-4** will hang up in the middle of a page.

The **VOX SENSITIVITY** probably will not have to be adjusted unless the **ZPI-4** is disconnecting in the middle of pages and this is happening before the time set by the **TIME OUT ADJUST** or there is a period of silence during a page longer than three seconds and the **ZPI-4** does not auto-disconnect.

To adjust the **VOX SENSITIVITY**, turn the pot counter clockwise to decrease the vox sensitivity and clockwise to increase it. The **VOX SENSITIVITY** should be decreased if the **ZPI-4** is auto-disconnecting in the middle of pages, and increased if it is not auto-disconnecting on periods of silence longer than three seconds.

- g. If the phone system provides a contact closure for night ring, connect a pair of wires from this closure to the **NIGHT CONTACTS** screw terminals. If the phone system provides ring signal for night ring, hook up a pair of wires from the phone system night ring output to the **NIGHT RING** screw terminals.
- h. Put DIP switch **4** to **OFF** to disable the **ZPI-4**'s dial tone.

### B. Multiple Units

While the **ZPI-4** is a four zone paging unit, it may be cascaded with an additional **ZPI-4** for a total of up to eight paging zones. The first **ZPI-4** is considered the "Master" unit, and the other unit is considered a "Slave". To use the **ZPI-4** in this way, install the Master unit and then use the following directions to install the Slave unit.

1. Select an amplifier mode, shown in **Installation** sections **A-C**.
2. Set DIP switch **2** to **ON** for both the Master and Slave. This sets both **ZPI-4s** for multiple units.
3. On the Slave unit, set DIP switch **3** to **ON**. On the Master unit, leave **OFF**.
4. If dial tone is desired, set DIP switch **4** on the Master unit to **ON**. This will enable dial tone for both units. On the Slave unit, DIP switch **4** should remain **OFF**.
5. On the Slave unit, set the **RING TRIP/TRUNK/PAGE PORT** switch to the same as the Master.
6. On the Slave unit, set the **TALK BATTERY** switch to **OFF**.
7. Connect a pair of wires from the **TELCO OUT** of the Master to the **TELCO IN** of the Slave.
8. Connect a pair of wires from the **MUSIC OUT** of the Master to the **MUSIC IN** of the Slave.
9. Connect a pair of wires from the **OUTPUT CONTACTS** of the Master to the **INPUT CONTACTS** of the Slave.
10. If night warble is desired through the Slave's zones, connect a pair of wires from the **NIGHT RING** or **NIGHT CONTACTS** (depending on which application you are using) of the Master to the **NIGHT RING** or **NIGHT CONTACTS** of the Slave.

*Note:* In the Trunk/Page Port mode, the Slave's night warble volume should be set to minimum (fully counter-clockwise). The Master's night warble volume will control the Slave's zones. In Ring Trip mode, the Master and Slave's night warble volumes will work independently.

11. Set the **TIME OUT ADJUSTMENT** on the Slave to the maximum time (clockwise).
12. Plug the power supply adapter into the power jack of the Slave, and the other end into a wall outlet.

# Operation

## A. Initiating a Page

### 1. Ring Trip Paging

To access the **ZPI-4** for ring trip paging, call the C.O., Centrex number or PABX/KSU station number the **ZPI-4** is connected to. The **ZPI-4** will answer on the first ring, produce dial tone (if enabled) and await Touch Tone entry for 10 seconds. If there is a Touch Tone entry, the **ZPI-4** activates the selected zone(s). If there is no Touch Tone entry in 10 seconds, the **ZPI-4** disconnects.

### 2. Paging from an Unused Phone System Trunk Input

To make a page with the **ZPI-4** installed on a spare trunk port, simply access the trunk connected to the **ZPI-4**. The **ZPI-4** will produce dial tone (if enabled), wait for Touch Tone entry, and activate the selected zone(s) when it sees a Touch Tone entry.

### 3. Paging from a Phone System's 600 Ohm Paging Port

To page in this situation, access the phone system's paging port. The **ZPI-4** will detect that a page is being initiated and wait for a Touch Tone entry. When it sees an entry, it activates the selected zone(s).

## B. Selecting Zones

### 1. Selecting Zones with One ZPI-4

Enter a single Touch Tone to select the zone or zones to be paged. After this entry has been made, the **ZPI-4** activates the selected zone(s). See diagram to the right.

Touch Tone	Zone(s)
1	1
2	2
3	3
4	4
5	1+2
6	2+3
7	3+4
8	1+2+3
9	2+3+4
0	1+2+3+4 (All)

### 2. Selecting Zones with Multiple ZPI-4's

To page all zones, enter a Touch Tone "0". The **ZPI-4** will activate all zones to which it is connected. Otherwise, enter two Touch Tones, with the first selecting which **ZPI-4** is being addressed, and the second selecting which zones connected to that **ZPI-4** are to be paged. If a Touch Tone "1" is entered as the first digit, the Master is selected. If a Touch Tone "2" is entered as the first digit, the Slave is selected. See diagrams to the right.

Touch Tone	Unit	Zone(s)
0	All	All
11	1	1
12	1	2
13	1	3
14	1	4
15	1	1+2
16	1	2+3
17	1	3+4
18	1	1+2+3
19	1	2+3+4
10	1	1+2+3+4

Touch Tone	Unit	Zone(s)
21	2	1
22	2	2
23	2	3
24	2	4
25	2	1+2
26	2	2+3
27	2	3+4
28	2	1+2+3
29	2	2+3+4
20	2	1+2+3+4

## C. Paging

After there has been a Touch Tone entry, the **ZPI-4** activates the selected zones and produces a paging alert tone. At this point the page can be spoken into the handset of the phone. In a **RING TRIP** or **PAGING PORT WITHOUT CONTACT CLOSURE** application, it is necessary to keep in mind that there is a time limit on the page, set by the **TIME OUT ADJUSTMENT**. Also, in these two applications, the vox voice detect circuit will disconnect the page if three seconds of silence elapse during the page. When finished paging, simply hang up.

**Product Support Line...715.386.8666**

**Fax Back Line...715.386.4345**

Due to the dynamic nature of the product design, the information contained in this document is subject to change without notice. Viking Electronics, and its affiliates and/or subsidiaries assume no responsibility for errors and omissions contained in this information. Revisions of this document or new editions of it may be issued to incorporate such changes.