

VIKING

TECHNICAL Practice

TELECOM SOLUTIONS FOR THE 21ST CENTURY

K-1900-3
Door Entry
Dialer

February 22, 2011

Provide Door Entry & Keyless Entry for up to 250 Apartments or Offices



The **K-1900-3** converts any touch tone phone into a multi-number auto dialer that will store up to 250 telephone numbers in non-volatile E² memory. Use with Viking's **K-1700-3** or **K-1900-8** phones to provide vandal resistant handsfree or handset communication.

When a call initiated by the **K-1900-3** is answered by an apartment or business tenant, a built-in contact closure may be activated to control an electric gate or door strike. Up to 250 keyless entry codes may also be programmed, providing tenants with keyless entry.

In addition, a master keyless entry code and up to five maintenance codes can be programmed. Calling activity and keyless entry use can be monitored using the log bus data output. The **K-1900-3** can be programmed locally or remotely using a standard Touch Tone phone. The **K-1900-3** has built-in user dialing restriction to help prevent unauthorized calls and toll fraud.

Features

- Compatible with Viking's vandal resistant **K-1700-3**, **K-1900-8** or any Touch Tone phone
- Non-volatile E² memory (no batteries required)
- Remotely or locally programmable
- **Stores 250 tenant Touch Tone phone numbers and keyless entry codes**
- Programmable tenant's relay activation code
- **Programmable master keyless entry code and five maintenance codes**
- Programmable call timer
- Multi-number dialer mode (for Kiosks, etc.)
- Ring-thru mode for calling the entry phone
- Normally open and normally closed (DPDT) relay contacts for controlling door strikes, magnetic locks, gates, etc.
- Auxiliary relay input to trigger a timed relay activation for postal locks, etc.
- Touch tone and pulse dialing toll restriction
- **Programmable allow/restrict for 911 and 311 outside calls**
- **Log bus data output for logging entry events**

Applications

- Complete apartment entry system when used with these Viking products...
 - **K-1700-3** Handsfree Speaker Phone (**DOD 157**) or
 - **K-1900-8** Wall Phone with Handset (**DOD 362**) and
 - **D-Series** Tenant Directories (**DOD 158**)
- Multi-tenant, gated communities
- Office parks and multi-business complexes
- Kiosks, ATMs, catalog sales, and interactive point of sale displays
- Reservation phones for hotels, airlines, car rentals, etc.

Specifications

Power: 120V AC/13.8V AC 1.25A, UL listed adapter provided
Dimensions: 89mm x 46mm x 132mm (3.5" x 1.8" x 5.2")
Shipping Weight: .74 kg (1.65 lbs)
Environmental: 0° C to 32° C (32° F to 90° F) with 5% to 95% non-condensing humidity
Talk Battery Output: 32V DC nominal
Connections: (2) RJ11 jacks, 10 pin screw terminal block
DTMF dialing speed: Normal - 120ms on/off, fast - 50ms on/off
Relay contact ratings: 5 Amps @ 30V DC/250V AC

Phone...715.386.8861

www.vikingelectronics.com

IF YOU HAVE A PROBLEM WITH A VIKING PRODUCT, PLEASE CONTACT: VIKING TECHNICAL SUPPORT AT (715) 386-8666

Our Technical Support Department is available for assistance Monday 8am - 4pm and Tuesday through Friday 8am - 5pm central time. So that we can give you better service, before you call please:

1. Know the model number, the serial number and what software version you have (see serial label).
2. Have your Technical Practice in front of you.
3. It is best if you are on site.

RETURNING PRODUCT FOR REPAIR

The following procedure is for equipment that needs repair:

1. Customer must contact Viking's Technical Support Department at 715-386-8666 to obtain a Return Authorization (RA) number. The customer MUST have a complete description of the problem, with all pertinent information regarding the defect, such as options set, conditions, symptoms, methods to duplicate problem, frequency of failure, etc.
2. Packing: Return equipment in original box or in proper packing so that damage will not occur while in transit. Static sensitive equipment such as a circuit board should be in an anti-static bag, sandwiched between foam and individually boxed. All equipment should be wrapped to avoid packing material lodging in or sticking to the equipment. Include ALL parts of the equipment. C.O.D. or freight collect shipments cannot be accepted. Ship cartons prepaid to:
Viking Electronics, 1531 Industrial Street, Hudson, WI 54016
3. Return shipping address: Be sure to include your return shipping address inside the box. We cannot ship to a PO Box.
4. RA number on carton: In large printing, write the R.A. number on the outside of each carton being returned.

RETURNING PRODUCT FOR EXCHANGE

The following procedure is for equipment that has failed out-of-box (within 10 days of purchase):

1. Customer must contact Viking's Technical Support at 715-386-8666 to determine possible causes for the problem. The customer MUST be able to step through recommended tests for diagnosis.
2. If the Technical Support Product Specialist determines that the equipment is defective based on the customer's input and troubleshooting, a Return Authorization (R.A.) number will be issued. This number is valid for fourteen (14) calendar days from the date of issue.
3. After obtaining the R.A. number, return the approved equipment to your distributor, referencing the R.A. number. Your distributor will then replace the product over the counter at no charge. The distributor will then return the product to Viking using the same R.A. number.
4. **The distributor will NOT exchange this product without first obtaining the R.A. number from you. If you haven't followed the steps listed in 1, 2 and 3, be aware that you will have to pay a restocking charge.**

LIMITED WARRANTY

Viking warrants its products to be free from defects in the workmanship or materials, under normal use and service, for a period of one year from the date of purchase from any authorized Viking distributor or 18 months from the date manufactured, whichever ever is greater. If at any time during the warranty period, the product is deemed defective or malfunctions, return the product to Viking Electronics, Inc., 1531 Industrial Street, Hudson, WI., 54016. Customer must contact Viking's Technical Support Department at 715-386-8666 to obtain a Return Authorization (R.A.) number.

This warranty does not cover any damage to the product due to lightning, over voltage, under voltage, accident, misuse, abuse, negligence or any damage caused by use of the product by the purchaser or others.

NO OTHER WARRANTIES. VIKING MAKES NO WARRANTIES RELATING TO ITS PRODUCTS OTHER THAN AS DESCRIBED ABOVE AND DISCLAIMS ANY EXPRESS OR IMPLIED WARRANTIES OR MERCHANTABILITY OR FITNESS FOR ANY PARTICULAR PURPOSE.

EXCLUSION OF CONSEQUENTIAL DAMAGES. VIKING SHALL NOT, UNDER ANY CIRCUMSTANCES, BE LIABLE TO PURCHASER, OR ANY OTHER PARTY, FOR CONSEQUENTIAL, INCIDENTAL, SPECIAL OR EXEMPLARY DAMAGES ARISING OUT OF OR RELATED TO THE SALE OR USE OF THE PRODUCT SOLD HEREUNDER.

EXCLUSIVE REMEDY AND LIMITATION OF LIABILITY. WHETHER IN AN ACTION BASED ON CONTRACT, TORT (INCLUDING NEGLIGENCE OR STRICT LIABILITY) OR ANY OTHER LEGAL THEORY, ANY LIABILITY OF VIKING SHALL BE LIMITED TO REPAIR OR REPLACEMENT OF THE PRODUCT, OR AT VIKING'S OPTION, REFUND OF THE PURCHASE PRICE AS THE EXCLUSIVE REMEDY AND ANY LIABILITY OF VIKING SHALL BE SO LIMITED.

IT IS EXPRESSLY UNDERSTOOD AND AGREED THAT EACH AND EVERY PROVISION OF THIS AGREEMENT WHICH PROVIDES FOR DISCLAIMER OF WARRANTIES, EXCLUSION OF CONSEQUENTIAL DAMAGES, AND EXCLUSIVE REMEDY AND LIMITATION OF LIABILITY, ARE SEVERABLE FROM ANY OTHER PROVISION AND EACH PROVISION IS A SEPARABLE AND INDEPENDENT ELEMENT OF RISK ALLOCATION AND IS INTENDED TO BE ENFORCED AS SUCH.

FCC REQUIREMENTS

This equipment complies with Part 68 of the FCC rules and the requirements adopted by the ACTA. On the side of this equipment is a label that contains, among other information, a product identifier in the format US:AAAEQ##TXXXX. If requested, this number must be provided to the telephone company.

The REN is used to determine the number of devices that may be connected to a telephone line. Excessive REN's on a telephone line may result in the devices not ringing in response to an incoming call. In most but not all areas, the sum of the REN's should not exceed five (5.0). To be certain of the number of devices that may be connected to a line, as determined by the total REN's, contact the local telephone company. For products approved after July 23, 2001, the REN for this product is part of the product identifier that has the format US:AAAEQ##TXXXX. The digits represented by ## are the REN without a decimal point (e.g., .03 is a REN of 0.3). For earlier products, the REN is separately shown on the label.

The plug used to connect this equipment to the premises wiring and telephone network must comply with the applicable FCC Part 68 rules and requirements adopted by the ACTA. If your home has specially wired alarm equipment connected to the telephone line, ensure the installation of this K-1900-3 does not disable your alarm equipment. If you have questions about what will disable alarm equipment, consult your telephone company or a qualified installer.

If the K-1900-3 causes harm to the telephone network, the telephone company will notify you in advance that temporary discontinuance of service may be required. But if advance notice isn't practical, the telephone company will notify the customer as soon as possible. Also, you will be advised of your right to file a complaint with the FCC if you believe it is necessary.

The telephone company may make changes in its facilities, equipment, operations, or procedures that could affect the operation of the equipment. If this happens, the telephone company will provide advance notice in order for you to make

the necessary modifications to maintain uninterrupted service.

If trouble is experienced with the K-1900-3, for repair or warranty information, please contact:

Viking Electronics, Inc., 1531 Industrial Street, Hudson, WI 54016 (715) 386-8666

If the equipment is causing harm to the telephone network, the telephone company may request that you disconnect the equipment until the problem is resolved.

Connection to Party Line Service is subject to State Tariffs. Contact the state public utility commission, public service commission or corporation commission for information.

WHEN PROGRAMMING EMERGENCY NUMBERS AND (OR) MAKING TEST CALLS TO EMERGENCY NUMBERS:

Remain on the line and briefly explain to the dispatcher the reason for the call. Perform such activities in the off-peak hours, such as early morning or late evenings.

It is recommended that the customer install an AC surge arrester in the AC outlet to which this device is connected. This is to avoid damaging the equipment caused by local lightning strikes and other electrical surges.

PART 15 LIMITATIONS

This equipment has been tested and found to comply with the limits for a Class A digital device, pursuant to Part 15 of the FCC Rules. These limits are designed to provide reasonable protection against harmful interference when the equipment is operated in a commercial environment. This equipment generates, uses, and can radiate radio frequency energy and, if not installed and used in accordance with the instruction manual, may cause harmful interference to radio communications. Operation of this equipment in a residential area is likely to cause harmful interference in which case the user will be required to correct the interference at his own expense.

Installation

A. Basic Wiring

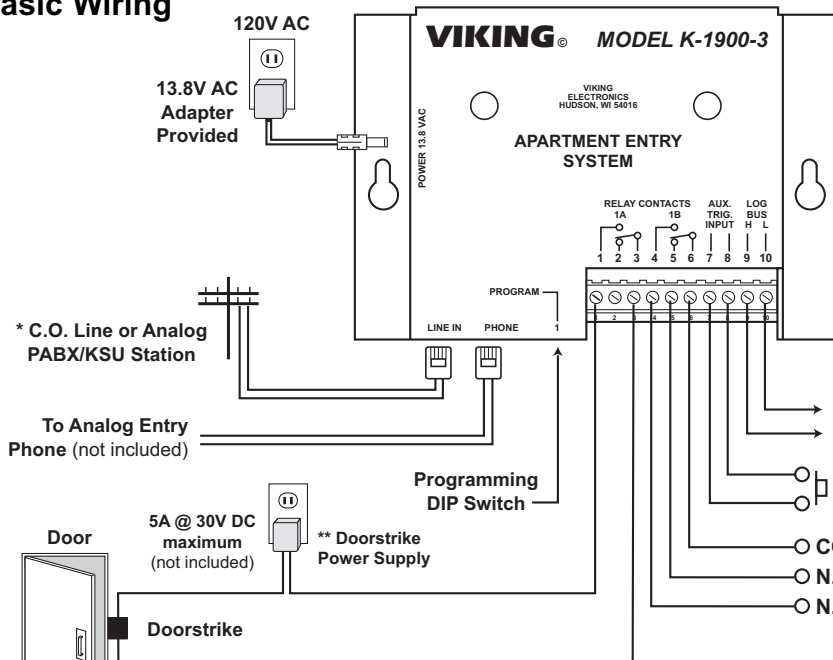

IMPORTANT: Electronic devices are susceptible to lightning and power station electrical surges from both the AC outlet and the telephone line. It is recommended that a surge protector be installed to protect against such surges. Contact Panamax at (800) 472-5555 or Electronic Specialists Inc. at (800) 225-4876.

* **Note:** When installing a K-1900-3 with a K-1700-3 phone on a low voltage and/or low loop current phone system extension, a **TBB-1A** Talk Battery/Loop Current boosting power supply may be required.

Need More Information on the TBB-1A?
Call (715) 386-4345 and select 630.

LOG BUS Data Output (see Installation section B): Download entry point data.

Auxiliary Relay Trigger Input: Momentary contact closure from postal lock, etc.

Secondary Relay Contacts: to trigger timed lights, camera control, etc.

Door Strike/Magnetic Locks: For door strike/magnetic lock information, contact your distributor or JLM Wholesale at (800) 522-2940.

B. Controls and Indicators

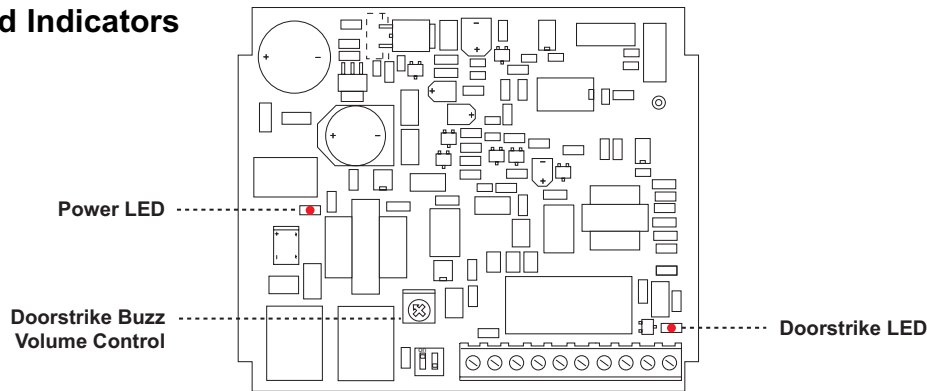

C. Optional LOG BUS Wiring

The **K-1900-3** transmits 1200 baud ASCII data from the **LOG BUS** screw terminals. Log Bus data is sent each time there is an entry point event, and includes the tenant memory location number dialed and whether the guest was allowed to enter, or the keyless entry code dialed and whether it was valid or not.

Communication Software Configuration	
Com	Your serial port (1-4)
Baud Rate	1200
Data Bits	8
Stop Bits	1
Parity	none
Flow Control	none

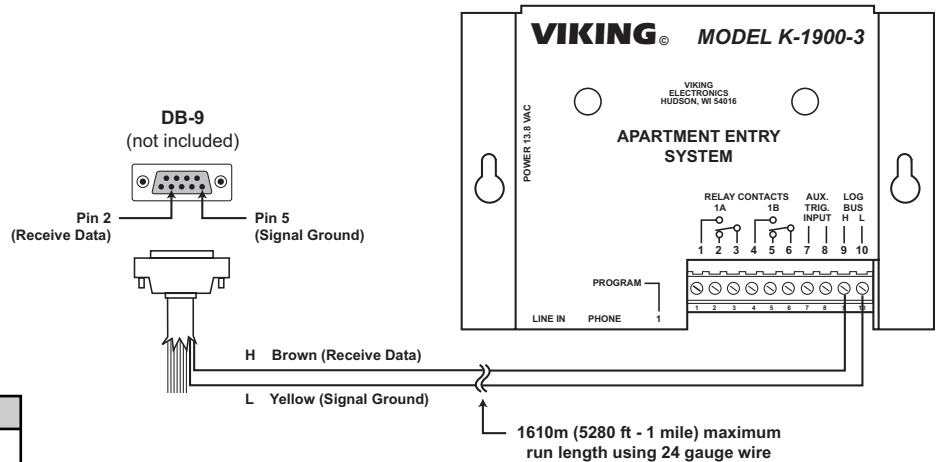

If the RS-232 input of a PC, printer, etc. is capable of receiving TTL level RS-232 signals, then the **LOG BUS** can be wired directly into the RS-232 "Receive Data" and "Signal Ground" pins to receive ASCII data. Windows "Hyper-Terminal" can be used to receive the data on a PC (use the settings in the chart to the left) or visit www.vikingelectronics.com to download free ENTRY LOGGER software (see **Operation** section E, "Entry Logger Software").

Programming

A. Accessing the Programming Mode

1. Remote Programming

- Connect the **LINE IN** port to a C.O. line or analog PABX/KSU station.
- From a touch tone phone, call the line connected to the **K-1900-3**.
- When the **K-1900-3** answers, enter "*" followed by the six digit security code, factory set to **845464** (see section **B** below). A double beep will indicate that programming has been entered.
- Program as shown in sections **B - G**.
- To exit programming, enter "##7" or do not enter any touch tones for approximately 20 seconds. Three beeps will be heard, followed by an automatic disconnect.

2. Local Programming Using the Security Code (from entry phone)

- Take the phone connected to the **PHONE** port off-hook.
- Enter a "*" followed by the six digit security code, factory set to **845464** (see section **B** below). A double beep will indicate that programming has been entered.
- Program as shown in section **B - G**.
- To exit programming, simply hang up the entry phone (push the "Call" button on the **K-1700-3**).

3. Local Programming Without the Security Code (from entry phone)

- Move dip switch 1 switch to the **ON** position (see right).
- Take the phone connected to the **PHONE** port off-hook. A double beep will indicate that programming has been entered.
- Program as shown in section **B - G**.
- When finished, dip switch 1 must be placed back in the **OFF** position for normal operation (see right).
- To exit programming, simply hang up the entry phone (push the "Call" button on the **K-1700-3**).

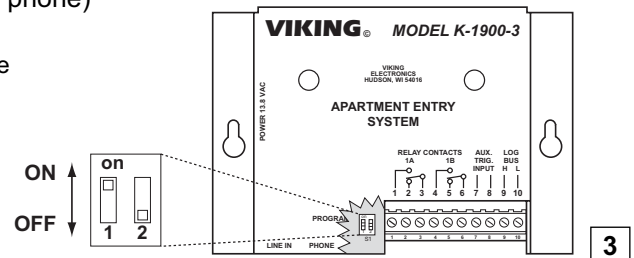

B. Security Code

A six digit number may be used to access the programming mode. The security code has been factory set to **845464** (V-I-K-I-N-G). It is recommended that you change the security code to a personal 6 digit number as follows:

1. Access programming as shown in section **A**.
2. Enter your new security code followed by **##5**.
3. To exit remote programming, enter **##7** or do not enter any touch tones for at least 20 seconds. To exit local programming simply hang up the entry phone.

Note: The security code must be six digits in length and **MUST NOT** contain a * or #. If you have forgotten your security code, see section “**A. Local Programming Without the Security Code.**”

C. Tenant’s Phone Numbers and Keyless Entry Codes

The **K-1900-3** can be programmed with up to 250 tenant phone numbers and up to 250 keyless entry codes, a master keyless entry code, and 5 maintenance entry codes. A tenant may activate the door strike from the entry phone by dialing a “#” followed by their keyless entry code. When a given tenant moves out of the complex, the phone number and keyless entry code for that tenant may be cleared without affecting any other tenant’s phone numbers or their keyless entry codes. Likewise, maintenance keyless entry codes may be assigned temporarily and cleared when no longer needed. **Note:** A keyless entry code may be programmed without a phone number.

1. Programming a Phone Number Only

While in programming, enter the tenant’s phone number + “#” + memory location number (**001 - 250**).

Example: 5551212 # 001

2. Programming a Phone Number and Keyless Entry Code

Note: Keyless entry codes **MUST** be programmed while programming the phone numbers into the memory locations (001 - 250). While in programming, enter the tenant’s phone number + “#*” + the keyless entry code for the tenant (4-6 digits) + “#” + memory location number (**001 - 250**). **Example:** 5551212 #* 123456 # 001

3. Programming a keyless entry code without a phone number

You are allowed to program a keyless entry code in a memory location without programming a phone number. This is useful when you need to assign keyless entry codes for people that are not tenants in the complex (guards, maintenance workers, etc.) The memory location becomes dedicated to keyless entry storage. This is programmed by entering “#*” (skipping the phone number entry) + the keyless entry code (4-6 digits) + “#” + the memory location (**001-250**). **Example:** #* 123456 # 001

4. Adding a Master Keyless Entry Code

The master keyless entry code is simply an additional keyless entry code in memory position 000. This is useful when you have a full 250 tenants and require one additional entry code for a non-tenant (guard, maintenance worker, etc.) This is programmed by entering “#*” (skipping the phone number entry) + the keyless entry code (4 - 6 digits) + “#” + the memory location **000**. **Example:** #* 123456 # 000

5. Adding a Maintenance Personnel Keyless Entry Code

Five maintenance personnel keyless entry codes are available, occupying memory positions 251 - 255. This is useful when you require additional entry codes for a non-tenant (guard, maintenance worker, etc.) These would ordinarily be assigned temporarily and then cleared when no longer needed (see number 6 below). This is programmed by entering “#*” + the keyless entry code (4 - 6 digits) + “#” + the memory location (**251 - 255**). **Example:** #* 123456 # 251

6. Deleting the Phone Number and/or Keyless Entry Code for One Memory Location

While in programming dial a “#” + memory location (**000 - 255**) to clear. **Note:** It is not possible to erase only the phone number or the keyless entry number. If either number needs to be changed, **BOTH** numbers must be reprogrammed.

7. Deleting All Phone Numbers and Keyless Entry Codes

While in programming, enter “###”. This will clear all phone numbers, entry codes and set all programming back to the factory settings. **CAUTION: All phone numbers and keyless entry codes will be permanently erased.**

D. Programming Examples

These examples would be entered after accessing programming as shown in section **A**.

Programming the K-1900-3...	Enter Digits
1. ...to dial 555-1234 when a “1” is entered at the entrance phone	5551234 #001
2. ...to dial a 9 and pause 3 seconds prior to dialing all numbers	9 ##2
3. ...to activate the door strike/magnetic lock when the tenant dials a “66”	66 ##4
4. ...to set keyless entry code for tenant 3 to “9876” with phone number 555-1234	5551234#*9876 #003
5. ...to set a keyless entry code for tenant 4 to “9876” without a phone number	#*9876 #004
6. ...to delete the keyless entry code and phone number for tenant 5	#005
7. ...to set a maximum call time of 10 minutes	10 ##6
8. ...to set the master keyless entry code to “123456”	#*123456 #000

E. Programming Features Quick Reference

Features	Enter Digits	- then -	Memory Location
Tenant's phone numbers: 001-002 (0-32 digits), 003-250 (0-16 digits)	phone number	+	#001-250
Tenant's phone numbers and keyless entry codes	phone number + #* + entry code +		#001-250
Keyless entry code only (4 - 6 digits)	#* + entry code	+	#001-250
Master keyless entry code (4 - 6 digits)	#* + entry code	+	#000
Maintenance personnel entry codes (4-6 digits)	#* + entry code	+	#251-255
Clear one phone number and/or keyless entry code	(no digits)	+	#001-250
PABX line access number: 1-3 digits + 3 sec pause (factory disabled)	1-3 digits	+	##2
Relay activation time: 1/2-99 sec (00 = 1/2 sec, factory set to 5 sec)	2 digits (00 - 99)	+	##3
Relay activation code*: 1-2 digits (factory set to 36)	1-2 digits (00 - 99)	+	##4
Security code (factory set to 845464)	6 digits (0 - 9)	+	##5
Maximum call time: 0-99 min (00 = disabled, factory set to 2 min)	2 digits (00 - 99)	+	##6
To exit remote programming	(no digits)	+	##7
Normal dialing speed (120ms on/off, factory setting)	*1		
Fast dialing speed (50ms on/off)	*2		
Apartment dialer mode (factory setting)	*3		
Multi-number dialer mode	*4		
Ring thru mode OFF (factory setting)	*5		
Ring thru mode ON	*6		
To add a 4 second pause anywhere in the dialing string	*7		
To add a 1 second pause anywhere in the dialing string	*8		
Enable 911 and 311 calling from entry phone (factory setting)	*9		
Disable 911 and 311 calling from entry phone	*0		
To add a * at any point in the dialing string	**		
To add a # at any point in the dialing string	*#		
Clear all phone numbers and keyless entry codes from memory and set all programming features back to factory settings	###		(Caution: Permanently erases ALL programming!)

* **Note:** When a single digit relay activation code is programmed (0-9), the activation Touch Tone must be held for a minimum of 150 milliseconds.

Notes: “*”, “#”, **pauses** occupy one digit space in memory. To clear a memory location, enter “#” + the memory location without any preceding digits. A **valid** programming entry will be indicated by a double beep. An invalid entry will be indicated with three beeps.

F. Programmable Maximum Call Time

The **K-1900-3** can be programmed to limit the call time on the entry phone. The maximum call time is programmable from “00” (no maximum call time) to “99” (99 minutes) and is factory set to “02” (2 minutes) (see **Programming**, section **D**). When the call timer is enabled (programmed to “01-99”), if a call exceeds the programmed time, both phones are provided with three beeps then disconnected, indicating the termination of the call. This limits unnecessary and lengthy conversations. When the call timer is disabled (programmed to “00”), there is no limit to the length of calls from the entry phone. Only a CPC disconnect signal from the telephone line, or hanging up the entry phone will disconnect the call.

G. Built-In Toll Restriction

The **K-1900-3** features built-in toll restriction. When the **K-1900-3** is in the **Apartment Dialer Mode** (factory setting), the unit will disconnect when it detects any Touch Tone or pulse dialing generated by the entry phone, after speed dialing has been completed. With the **K-1900-3** in the **Multi-Number Dialer Mode**, the unit will disconnect when it detects any flashes or pulse dialing generated by the phone after speed dialing has been completed.

Operation

A. Apartment Dialer Mode (factory setting)

When a visitor accesses the entry phone, simulated dial tone is heard. After the visitor enters the appropriate one to three digit tenant number (equal to the memory location in programming), the **K-1900-3** dials the tenant's phone number and bridges the phone line to the entry phone. If an unprogrammed tenant number is entered, a simulated fast busy signal will be heard on the entry phone. When the tenant confirms the visitors identity, a one or two digit relay activation code may be entered from the tenant's phone. Two beeps will indicate that a valid activation code has been entered. A buzzing sound is then heard on the entry phone to indicate the door strike has been activated. The level of this sound can be controlled independently from other tones by adjusting the Doorstrike Buzz Volume Control (see **Installation** section **B**). If an incorrect relay activation code is entered, the unit will disconnect. A simulated fast busy signal will also be returned to the entry phone if the telephone line has become disconnected. A tenant may use their personal keyless entry code to let themselves in by taking the entry phone off-hook and entering a “#” followed by their (4 - 6 digit) personal keyless entry code. **Note:** To avoid busy signals on the entry phone, call waiting is recommended on each tenant's phone line.

B. Multi-Number Dialer Mode (relay activation codes ignored after dialing)

This mode is useful when using the **K-1900-3** in applications other than apartment/multi-tenant entry, such as Kiosks or any other user selectable speed dialing application when 250 phone numbers or less are required. An off-hook on the phone port will return simulated dial tone. The user can then enter their one to three digit speed dial memory location. The **K-1900-3** speed dials the phone number programmed in that memory location then bridges the phone to the line. The user is now free to dial any Touch Tone numbers required to steer through automated attendants, etc. If the user attempts to pulse dial or flash the line for fresh dial tone (to make a toll call), the **K-1900-3** will restrict the call by switching the phone back to artificial talk battery with a simulated busy signal. **Note:** *If this phone is to receive in-bound calls, select the Ring Thru Mode (see **Operation** section C). Also, keyless entry codes work, but there is no relay activation from the tenant's phone.*

C. Ring Thru Mode

If the Ring Thru mode is selected (see **Programming** section E), incoming calls are allowed to ring through the **K-1900-3** to the entry phone connected to the phone port. If the door phone has an auto-answer feature, this will allow the user to "monitor" the entry way. The **K-1900-3** is still watching for the security code and will seize the line if a valid code is detected. In this manner, the **K-1900-3** may still be remotely programmed. In this mode the relay activation code may also be used. If the Ring Thru mode is turned off, the **K-1900-3** will answer all inbound calls. **Note:** *To utilize the Ring Thru mode with a **K-1700-3** entry phone, automatic answer must be enabled on the **K-1700-3** (dip switch setting). See the **K-1700-3** Technical Practice (Fax Back Document 157).*

D. Data Logging

Each time there is an entry point event, the **K-1900-3** will transmit 1200 baud ASCII data out of its **LOG BUS** screw terminals. An example of 5 different entry events is shown below. The **K-1900-3** outputs entry event data in real time, but does not time stamp.

Examples:	Simulated LOG BUS Output			
Non-Valid Keyless Attempt	1	N	KLS	8132
Valid Keyless Entry	1	V	KLS	708132
A guest was granted entry by tenant in memory location 007	1	V	GST	007
A guest talked to the tenant in memory location 059, but was not granted entry	1	N	GST	059
911 was dialed at the entry phone	1	V	EMR	911

Entry Point ID Number (always 1) →

If the entry attempt Valid (V) or Not Valid (N) →

Keyless code entered (keypad) or tenant memory location number if a guest called (KLS) for keyless code, (GST) if a guest called a tenant, or (EMR) if a guest called 911 or 311 →

E. Entry Logger Software

Visit www.vikingelectronics.com to download free **ENTRY LOGGER** software. The software provides transaction logging for the **ES-1**, **K-1900-3** and **C-4000** Entry Controller systems. Compatible with any Windows based PC running Windows 98 or higher, the software adds time and date stamps to each transaction, and allows user printing, record saving, and complete search capabilities.

IMPORTANT: *Viking Electronics will NOT support computer software or hardware problems. If you experience these problems, research your hardware/software instruction manuals or contact the manufacturer's technical support.*

Product Support Line...715.386.8666

Fax Back Line...715.386.4345

Due to the dynamic nature of the product design, the information contained in this document is subject to change without notice. Viking Electronics, and its affiliates and/or subsidiaries assume no responsibility for errors and omissions contained in this information. Revisions of this document or new editions of it may be issued to incorporate such changes.

Please use these charts to record the numbers programmed into the **K-1900-3** (use pencil).

Security Code (##5): _____ Relay Activation Code (##4): _____ Master Keyless Entry Code (#00): _____

Memory Location	Apt #	Tenant's Phone #	Entry Code #
001			
002			
003			
004			
005			
006			
007			
008			
009			
010			
011			
012			
013			
014			
015			
016			
017			
018			
019			
020			
021			
022			
023			
024			
025			
026			
027			
028			
029			
030			
031			
032			
033			
034			
035			
036			
037			
038			
039			
040			
041			
042			
043			
044			
045			
046			
047			
048			
049			
050			
051			
052			
053			
054			
055			
056			
057			
058			
059			
060			
061			
062			
063			
064			
065			
066			
067			
068			
069			
070			
071			
072			
073			
074			
075			

Memory Location	Apt #	Tenant's Phone #	Entry Code #
076			
077			
078			
079			
080			
081			
082			
083			
084			
085			
086			
087			
088			
089			
090			
091			
092			
093			
094			
095			
096			
097			
098			
099			
100			
101			
102			
103			
104			
105			
106			
107			
108			
109			
110			
111			
112			
113			
114			
115			
116			
117			
118			
119			
120			
121			
122			
123			
124			
125			
126			
127			
128			
129			
130			
131			
132			
133			
134			
135			
136			
137			
138			
139			
140			
141			
142			
143			
144			
145			
146			
147			
148			
149			
150			

Memory Location	Apt #	Tenant's Phone #	Entry Code #
151			
152			
153			
154			
155			
156			
157			
158			
159			
160			
161			
162			
163			
164			
165			
166			
167			
168			
169			
170			
171			
172			
173			
174			
175			
176			
177			
178			
179			
180			
181			
182			
183			
184			
185			
186			
187			
188			
189			
190			
191			
192			
193			
194			
195			
196			
197			
198			
199			
200			
201			
202			
203			
204			
205			
206			
207			
208			
209			
210			
211			
212			
213			
214			
215			
216			
217			
218			
219			
220			
221			
222			
223			
224			
225			

Memory Location	Apt #	Tenant's Phone #	Entry Code #
226			
227			
228			
229			
230			
231			
232			
233			
234			
235			
236			
237			
238			
239			
240			
241			
242			
243			
244			
245			
246			
247			
248			
249			
250			

Additional Entry Codes

Memory Location	Description	Entry Code #
251	Maintenance Personnel	
252	Maintenance Personnel	
253	Maintenance Personnel	
254	Maintenance Personnel	
255	Maintenance Personnel	

Check the Features In Use

- _____ *1 Normal Dialing Speed
- _____ *2 Fast Dialing Speed
- _____ *3 Apartment Dialer Mode
- _____ *4 Multi-Number Dialer Mode
- _____ *5 Ring Thru Mode OFF
- _____ *6 Ring Thru Mode ON
- _____ *9 Enable 911 and 311 Calling from Entry Phone
- _____ *0 Disable 911 and 311 Calling from Entry Phone

Other Features

- _____ (1-3 digits) ##2: PABX Line Access Number
- _____ (2 digits) ##3: Relay Activation Time
- _____ (2 digits) ##6: Maximum Call Time