



APPLICATION Note

TELECOM SOLUTIONS FOR THE 21ST CENTURY

Long Speaker Runs with the PA-2A and PA-15

July 10, 2013

Minimize the Loss of Audio in Long Speaker Runs

It is possible to install long speaker runs with the PA-2A and PA-15.

To minimize the loss of audio power in long speaker runs, a transformer is required at both the amplifier end and at the speaker end of a long wire run. A minimum of two transformers are always required (see part numbers in the Installation sections). The transformer at the amplifier is referred to as the step-up transformer; the transformer at the speaker is referred to as the step down transformer.

Phone...715.386.8861

<http://www.vikingelectronics.com>



Model PA-2A



Model PA-15

Installation

A. Step Up Transformer

1. Connecting the Audio Output

At the amplifier, connect the **8 OHM AUDIO OUTPUT** to the **8 OHM** and **COM** taps of the step-up transformer's secondary coil as shown. See chart below for pin selections.

Model	Output Pins
PA-2A	9 & 10
PA-15	1 & 2

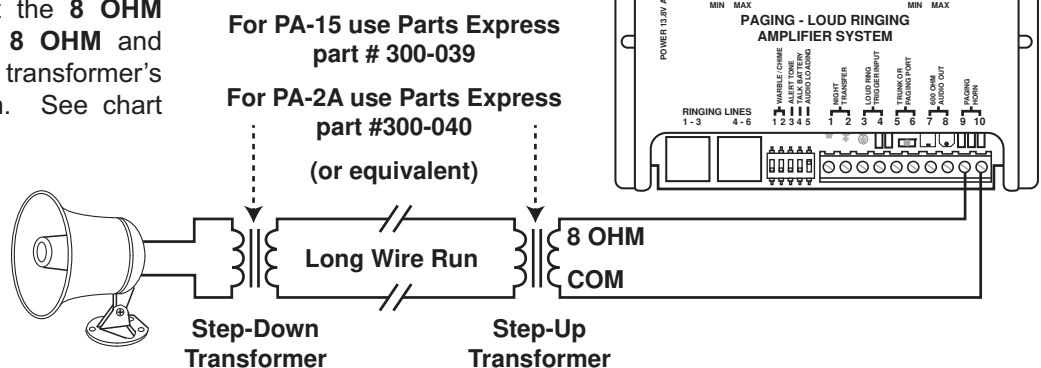

2. Selecting the Coil Tap

Select the step-up transformer's primary coil tap, which closest matches the amplifier's rated wattage output and connect these taps to the beginning of the long wire run (see the chart to the right).

Model	Parts Express Part #	Tap
PA-2A	300-040	2.5 Watt
PA-15	300-039	15 Watt

B. Step Down Transformers

The number of step-down transformers and the taps used will depend on the number of speakers and the distances between the speakers as shown below.

1. Using Only One Speaker

If only one speaker is used, only one step-down transformer would be required. Connect the speaker to the **8 OHM** and **COM** taps of the step-down transformer's secondary coil as shown. Connect the same wattage taps (as those used on the step-up transformer's primary coil) of the step-down transformer's primary coil to the end of the long wire run.

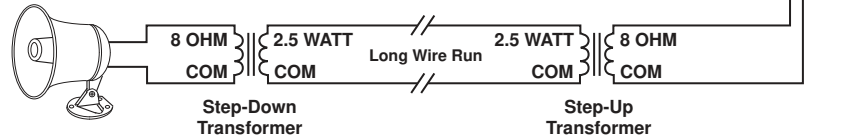

2. Using Two Speakers (close together)

In using two speakers located close together, connect the two speakers in parallel and connect them to the **4 OHM** and **COM** taps of the step-down transformer's secondary coil as shown. Connect the same wattage taps (as those used on the step-up transformer's primary coil) of the step-down transformer's primary coil to the end of the long wire run.

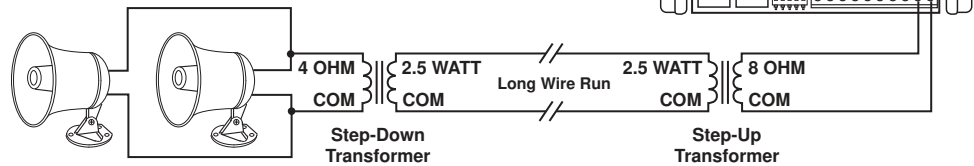

3. Multiple Speakers or Speakers Located Far Apart

Multiple speakers (three or more), or speakers located far apart will require multiple step-down transformers. Connect each speaker to the **8 OHM** and **COM** of each step-down transformer's secondary coil. To determine which taps to use on each step-down transformer's primary coil, divide the wattage of the tap used on the step-up transformer's primary coil (2.5 for a **PA-2A**, 15 for a **PA-15**) by the number of speakers and connect each of the step-down transformer's primary coils to the end of each long wire run.

Example (shown below): A **PA-2A** driving four speakers located far apart from each other would equal 2.5 watts divided by 4 which is 0.625 watts, so use the **.625 WATT** and **COM** taps on each step-down transformer's primary coil.

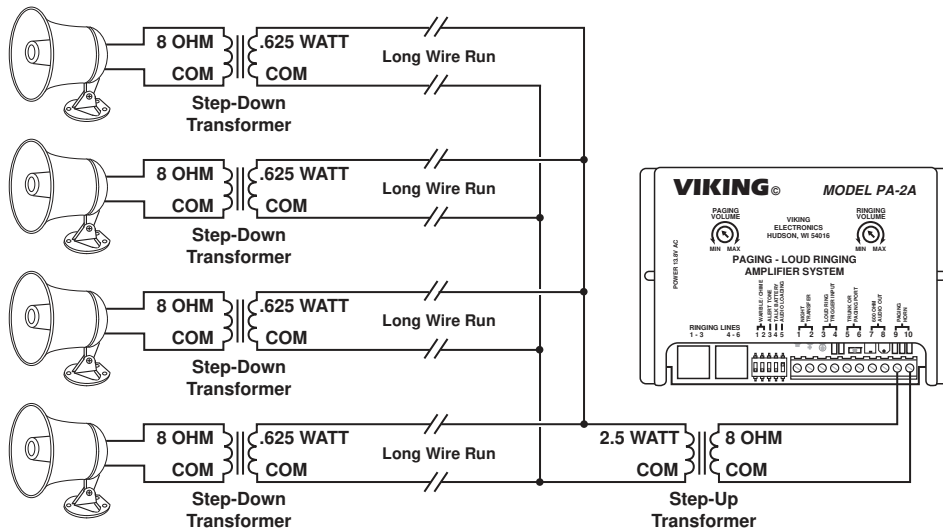

Product Support Line...715.386.8666

Fax Back Line...715.386.4345

Due to the dynamic nature of the product design, the information contained in this document is subject to change without notice. Viking Electronics, and its affiliates and/or subsidiaries assume no responsibility for errors and omissions contained in this information. Revisions of this document or new editions of it may be issued to incorporate such changes.