

Add High Power Paging, Loud Ringing, and Background Music to Any Analog Phone System



The **PA-250** is a 250 Watt 70V Telecom Paging Amplifier that can drive up to two hundred fifty (250) 70V speakers and/or paging horns (each speaker set to “1 Watt tap”). The small 1U rack size chassis is possible because the **PA-250** uses new amplifier technology that is 3 times more efficient than old designs competitors use. The high efficiency of the **PA-250** means much less heat dissipation, smaller size, higher reliability, and lower cost.

There are many advantages of using a 70V distributed audio paging system, such as being able to put more speakers on a wire run, having longer speaker wire runs, using smaller gauge wire, and being able to set the volume of each speaker independently.

The **PA-250** connects to any type of analog telecom interface, such as a Paging Port, Trunk Input, Analog Station, FXO (Loop Start), or FXS (Ring Trip).

The **PA-250** has a direct microphone input for paging, as well as other inputs including Background Music, Aux Input, and a variety of loud ringing and chime options. A 600 Ohm output allows more paging amplification to be added if needed.

The **PA-250** features individual level controls with LED indicators for each input, automatic peak limiting, multiple amplifier protection modes, an adjustable Automatic Level Control, and Bass & Treble controls.

Touch tone programming allows users to set input priorities, pre-page alert tones, different chime sounds, and numerous telecom settings for universal telecom system compatibility.

The Aux Input allows the addition of another audio source such as a clock-controlled tone generator (Viking model **CTG-1A** or **CTG-2A**), or emergency notification system (Viking model **DNA-510**).

Features

- Powerful 70V amplifier drives up to 250 Watt load
- Page from any analog telecom port or a direct microphone
- Auxiliary and background music inputs
- Individual and master volume controls
- Bass and treble controls
- LEDs show audio level and activity
- Programmable input priorities
- Choose between 3 different chime sounds
- Provides Loud Ringing / Night Bell
- Night Transfer switch input
- 600 Ohm output to drive additional amplifiers
- Adjustable Automatic Level Control
- Peak limiter and multiple protection modes

Applications

- Paging systems requiring 8 to 250 speakers
- Paging from virtually any POTS, Centrex PABX, digital or IP phone system's analog port
- Installations that can utilize the below advantages of a 70V distributed audio system:
 - Longer wire runs using smaller gauge speaker wire to save costs
 - Many speakers can be connected on the same wire run to save costs
 - Set each speaker's volume individually using its own power taps

Specifications

Power: 100V to 240V AC, 50 to 60Hz

Dimensions: approx. 19" x 1.75" x 6" (483mm x 44.5mm x 153mm)

Shipping Weight: lbs (kg)

Environmental: 0°C to 32°C (32°F to 90°F) with 5% to 95% non-condensing humidity

Talk Battery: 42V DC

Paging Output: Capable of driving 250 Watt load of 70V speakers

Connections: (1) 3.5mm (1/8") audio jack, (22) removable cage clamp screw terminals, (2) IEC C8 AC power inlets

Power Cord: Dual IEC C7 plugs "Y" power cord included

Information: 715-386-8861
www.VikingElectronics.com

Features Overview

! **IMPORTANT:** Electronic devices are susceptible to lightning and power station electrical surges from both the AC outlet and the telephone line. It is recommended that a surge protector be installed to protect against such surges.

PA-250 Front View



- MIC:** Microphone Input volume control and LED showing audio input level
- ALC:** Automatic Level Control adjustment for MIC and PAGE inputs
- PAGE:** Paging Input volume control and LED showing both activity and audio level
- AUX:** Auxiliary Input volume control and LED showing both activity and audio level
- RING:** Volume control and LED indicator for Chime and Loud Ringing tones
- MUSIC:** Volume control for Background Music Input
- BASS:** Low frequency tone control
- TREBLE:** High frequency tone control
- MASTER VOLUME:** Master volume control and LED level indicator for setting Peak Limiting
- POWER:** LED indicating power is on (winks off to indicate an overload condition)

PA-250 Back View



- SPEAKERS:** Connect up to two hundred fifty (250) 70V or 25V speakers and/or paging horns
- AC POWER INPUT:** Connect to 100V to 240V AC power using the included "Y" power cord
- CHIME TRIG:** To trigger one of three different chime tones
- NIGHT TRANSFER:** To enable (open), or disable (closed) loud ringing
- RINGING LINE:** A ringing FXS or PABX analog station will trigger loud ringing
- BACKGROUND MUSIC INPUT:** 3.5mm jack for connecting music source
- 600 OHM OUTPUT:** Output for driving additional amplifiers
- SHIELD:** Analog ground
- AUX INPUT:** Auxiliary analog input
- PAGE CONTACT:** Contact closure input for telecom paging
- PAGE INPUT:** Analog input for telecom paging
- PROG:** Push button to access programming mode without security code
- FXO/FXS/PAGE PORT:** Slide switches for FXO (Loop Start), FXS (Ring Trip), or Page Port telecom paging
- PTT:** Push-to-Talk input for microphone
- MIC IN:** Low level dynamic microphone input

Installation

A. Microphone Loud Paging

Step 1	Connect a balanced low impedance microphone to the MIC IN terminals (pins 1 & 2).
Step 2	Connect the microphone's shield wire to the SHIELD terminal (pin 3).
Step 3	Connect the microphone's Push-to-Talk leads (if available) to the PTT terminals (pins 3 & 4).
Step 4	If the microphone does not have Push-to-Talk, the MIC VOX feature must be enabled (enter 1#42 in programming), see Programming section.
Step 5	Adjust the front panel MIC trim pot so the MIC LED flashes with mic audio.

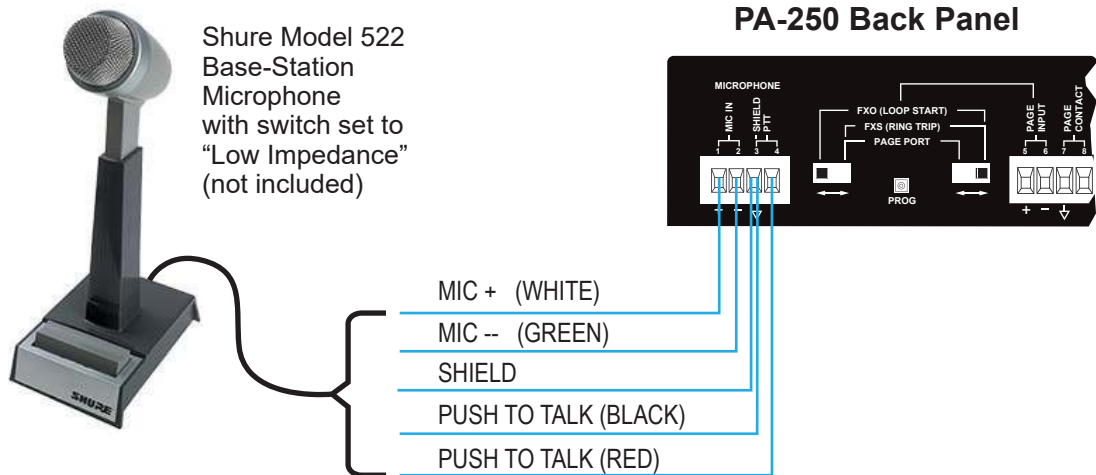

B. Telecom Loud Paging

1. FXO (Loop Start) for Line Input (Trunk Port) or Analog Phone

Step 1	Move both back panel slide switches to the FXO (LOOP START) position.
Step 2	Connect the phone system's Trunk Port / FXO / or an analog phone to the PAGE INPUT terminals (pins 5 & 6).
Step 3	Adjust the front panel PAGE trim pot so the PAGE LED flashes with page audio.

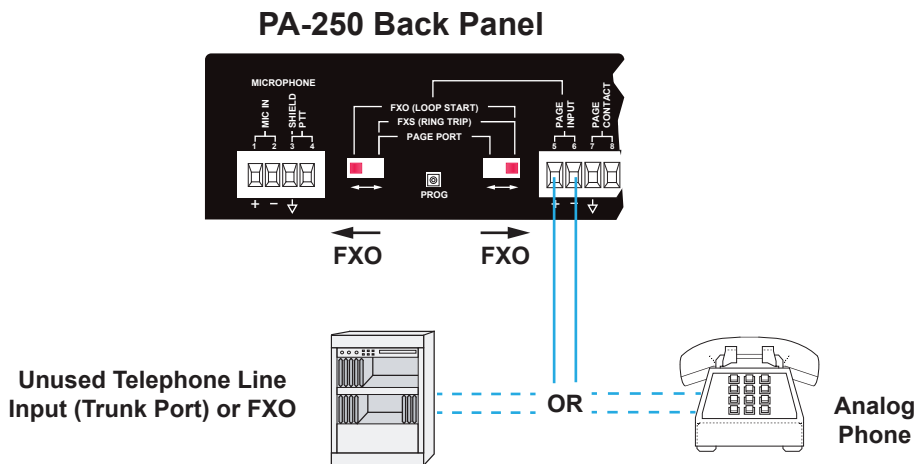

2. FXS (Ring Trip) for Use with an Analog Station

Step 1	Move both back panel slide switches to the FXS (RING TRIP) position.
Step 2	Connect an Analog Station / FXS / or Ringing Line to the PAGE INPUT terminals (pins 5 & 6).
Step 3	Adjust the front panel PAGE trim pot so the PAGE LED flashes with page audio.

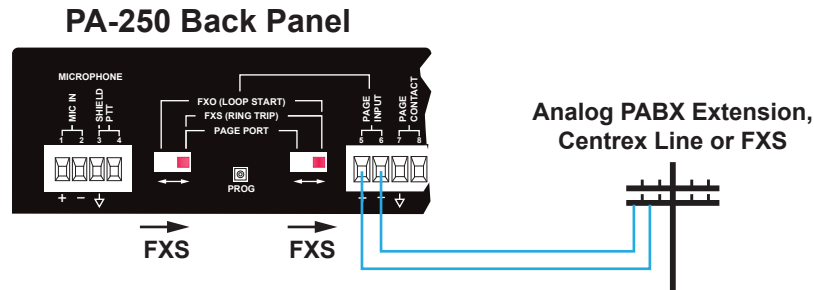

3. Paging Port

Step 1	Move both back panel slide switches to the PAGING PORT position.
Step 2	Connect the phone system's Paging Port output to the PAGE INPUT terminals (pins 5 & 6).
Step 3	Connect the phone system's paging contacts (if available) to the PAGE CONTACT terminals (pins 7 & 8).
Step 4	If paging contacts are not available, the PAGE VOX feature must be enabled (enter 1#43 in programming), see Programming section.
Step 5	Adjust the front panel PAGE trim pot so the PAGE LED flashes with page audio.
Step 6	If the Page Port audio is coming from an RCA jack, and hum or buzz is present in the audio, the RCA cable's shield may need to be grounded on the PA-250 side. This can be done by connecting the cable's shield to the Ground Terminal (pin 7).

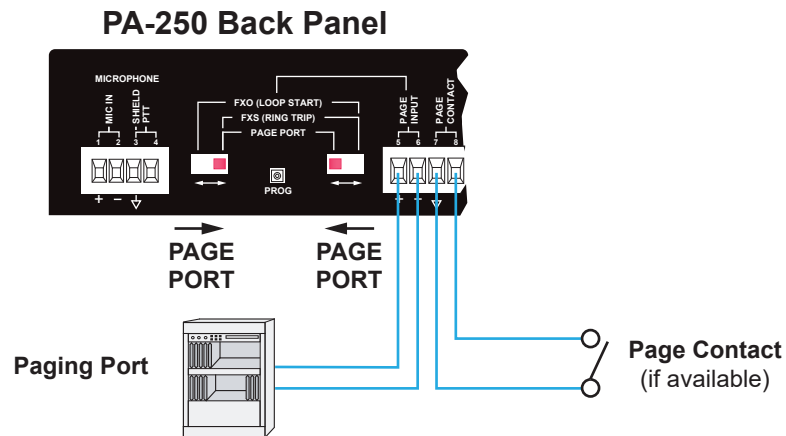

C. Auxiliary Input

Step 1	Connect any line level source to the AUX IN terminals (pins 9 & 10)
Step 2	Adjust the front panel AUX trim pot so the AUX LED flashes with Aux audio. If AUX audio sounds distorted, its input is probably being overdriven. Turn down the front panel AUX trim pot until the sound is clear.
Step 3	If the auxiliary audio is coming from an RCA jack, and hum or buzz is present in the audio, the RCA cable shield may need to be grounded on the PA-250 side. This can be done by connecting the cable shield to the SHIELD terminal (pin 11).

NOTE: A speaker level signal can be connected to the **AUX IN** terminals, as long as the front panel **AUX** trim pot is turned down low enough to not overdrive the input.

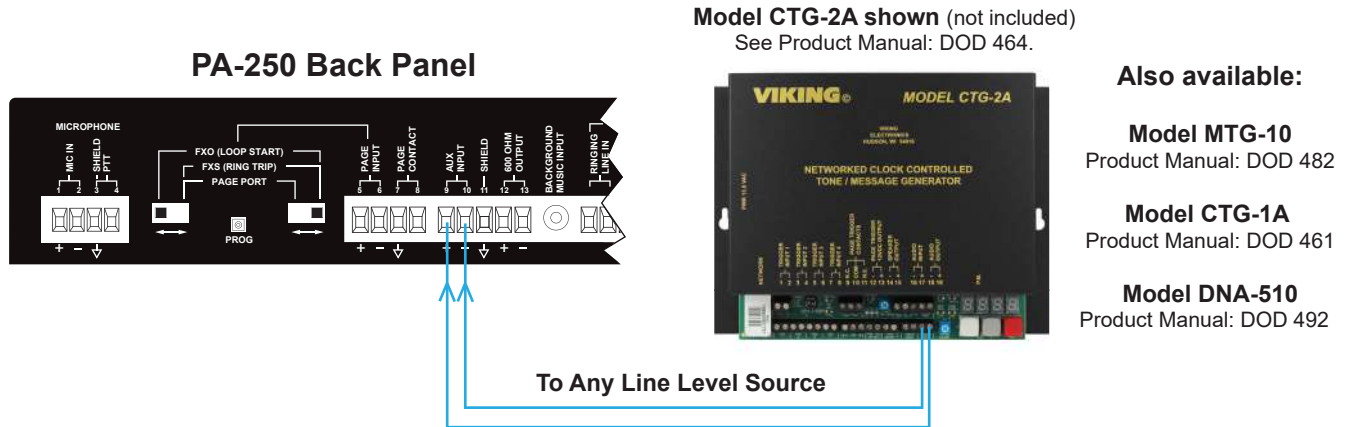

D. 600 Ohm Output for Additional Paging Power

When more than a 250 Watt load is required, a Viking model **PP-250** can be added to achieve a 500 Watt load capability.

Step 1	Connect the PA-250's 600 OHM OUTPUT terminals (pins 12 & 13), to the PP-250's LINE INPUT terminals (pins 1 & 2).
Step 2	If a shield cable is used, connect the cable's shield at both ends.
Step 3	Adjust the PP-250's front panel INPUT trim pot so the LED flashes with page audio.

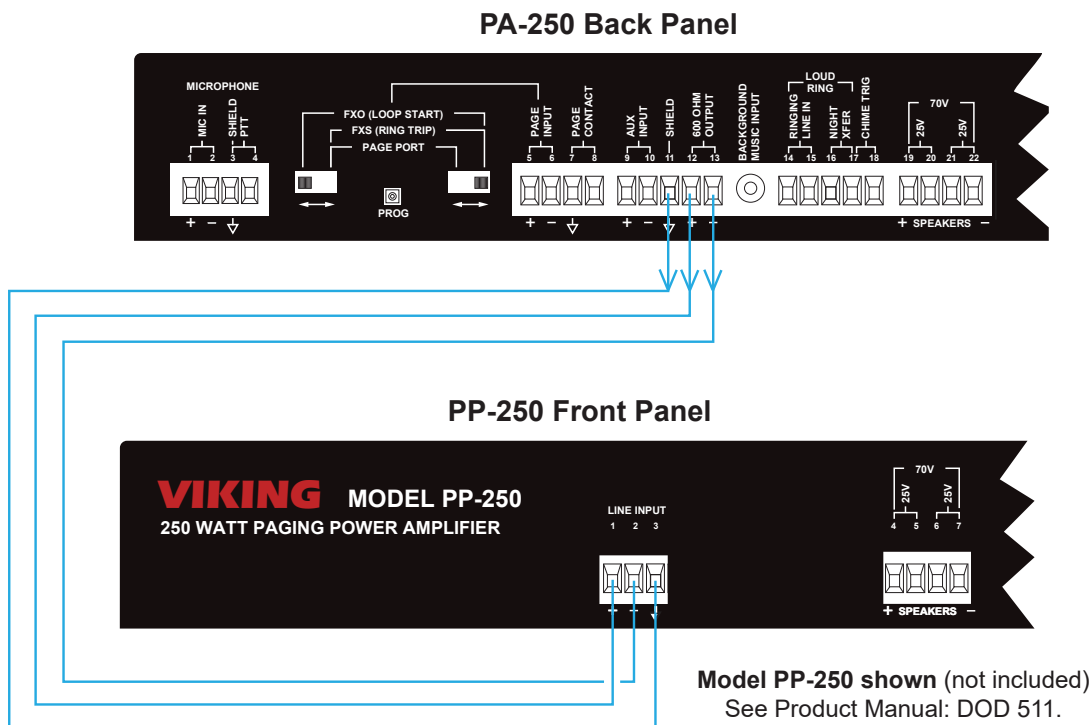

E. Background Music Input

Step 1	Connect background music source to BACKGROUND MUSIC INPUT jack using a 1/8" (3.5mm) cable.
Step 2	Adjust the front panel music trim pot to the desired level.

NOTE: Background music will play only when all other audio inputs are idle.

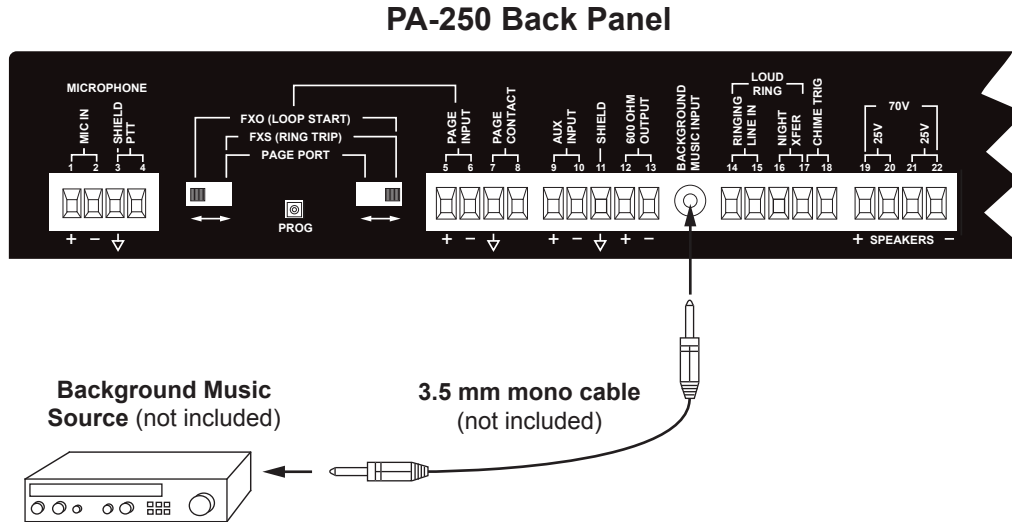

F. Loud Ringing / Night Transfer

1. Ringing Analog Line

Step 1	Connect a ringing line, FXS Port or ringing Analog PABX Station to the RINGING LINE IN terminals (pins 14 & 15).
Step 2	A Night Transfer switch may be added to the NIGHT XFER terminals (pins 16 & 17) to enable and disable loud ringing.
Step 3	The front panel RING trim pot can be used to adjust ringing and chime tone volumes.

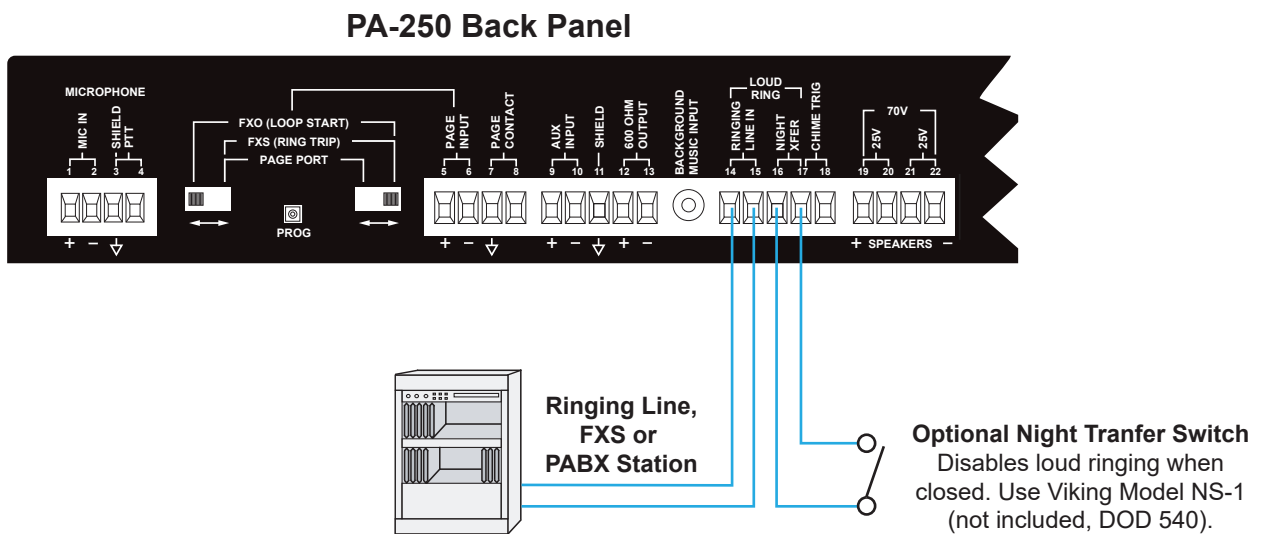

2. Using the Chime Trigger Input for a Dry Contact (Common Audible) Closure from the Phone System

Step 1	Connect a phone system's common audible dry contact closure to the CHIME TRIG terminals (pins 17 & 18).
Step 2	Chime Trigger is factory set to the "Door Chime" (dingong) sound, but can be programmed to the "Electronic Warble" sound (see Programming section K).
Step 3	The front panel RING trim pot can be used to adjust ringing, chime tones, and alert tone volumes.

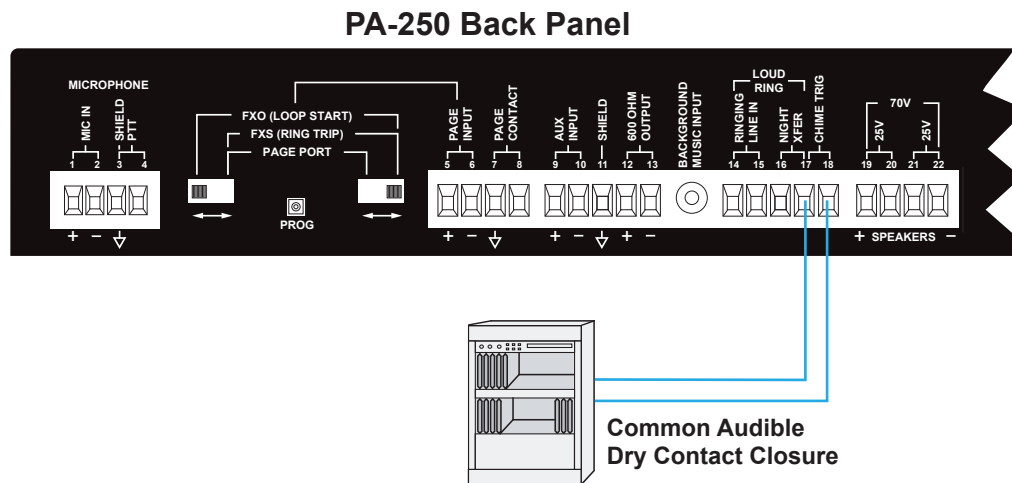

G. Chime Trigger

Step 1	Connect any momentary contact closure (such as a non-lighted door bell button) to the CHIME TRIG terminals (pins 17 & 18).
Step 2	A momentary closure will trigger a "Door Chime" (ding-dong) tone, but can be programmed to one of three other sounds (see Programming section K).
Step 3	The front panel RING trim pot can be used to adjust ringing, chime tones, and alert tone volumes.

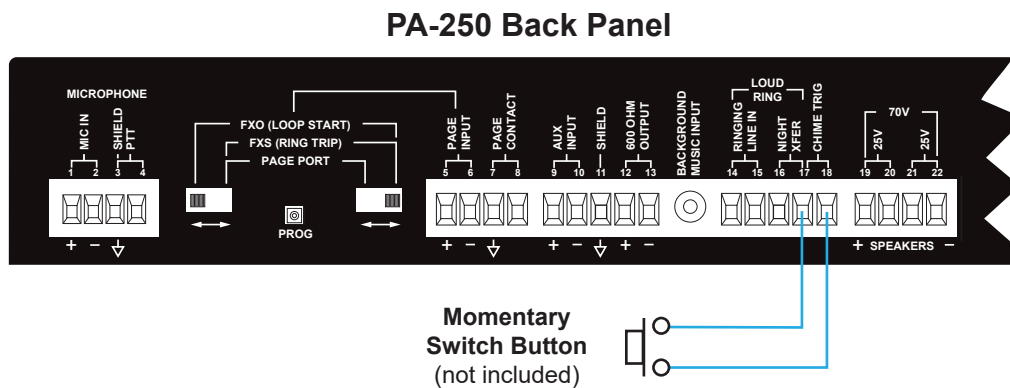

H. Speakers

Step 1	Connect 70V speakers across the 70V SPEAKERS terminals (pins 19 & 22).
Step 2	If using 25V speakers, connect half of them across the 25V SPEAKERS terminals (pins 19 & 20), and the other half across the 25V SPEAKERS terminals (pins 21 & 22), so that the power load is balanced between the two outputs.
Step 3	Check the power tap of each speaker connected, and be sure the sum of all the speakers connected does not exceed 250 Watts. For example, if there are 40 speakers, and all are wired to their 5 Watt taps, the amplifier is driving a 200 Watt load. Since the PA-250 is capable of driving a 250 Watt load, additional speakers could be added, or some of the existing speakers could be tapped at a higher wattage setting to play louder. If the total speaker load goes “over budget” (greater than 250 Watt load), either remove some speakers, or use lower power taps to get down to a 250 Watt load. If more than 250 Watt load is needed, a PP-250 can be added as shown in Installation , section D.

PA-250 Back Panel

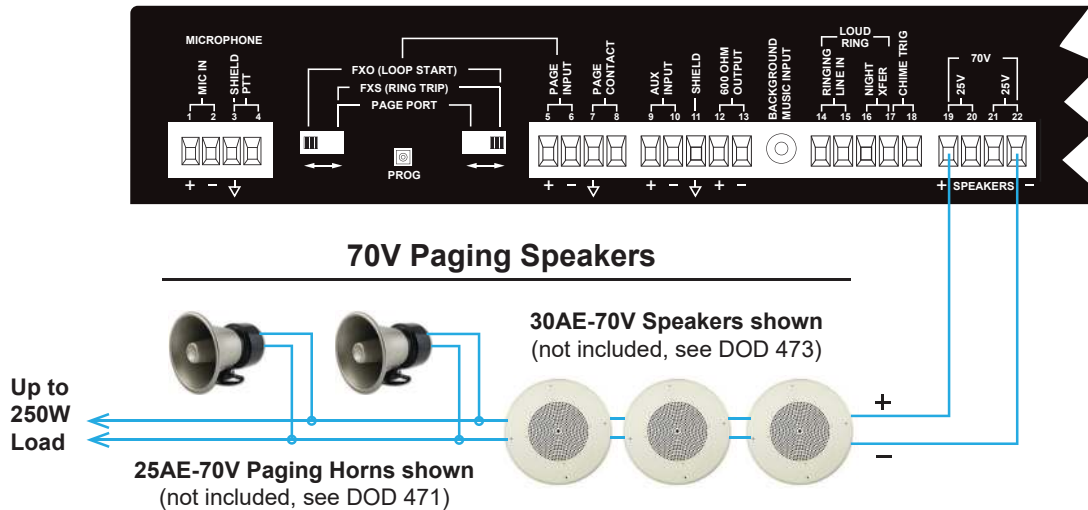

NOTE: For wire run lengths up to 500 feet, use #18 gauge or larger speaker cables. For wire run lengths up to 1000 feet, use #16 gauge or larger speaker cables. For wire run lengths up to 1500 feet, use #14 gauge or larger speaker cables, etc.

I. AC Power Input

Step 1	Connect both IEC C7 plugs from the supplied “Y” AC power cord into the two AC POWER INPUTS on the back of the PA-250 .
Step 2	Once all other connections are made, power up the PA-250 by plugging the AC power plug end of the supplied “Y” AC power cord into a power outlet.

PA-250 Back Panel

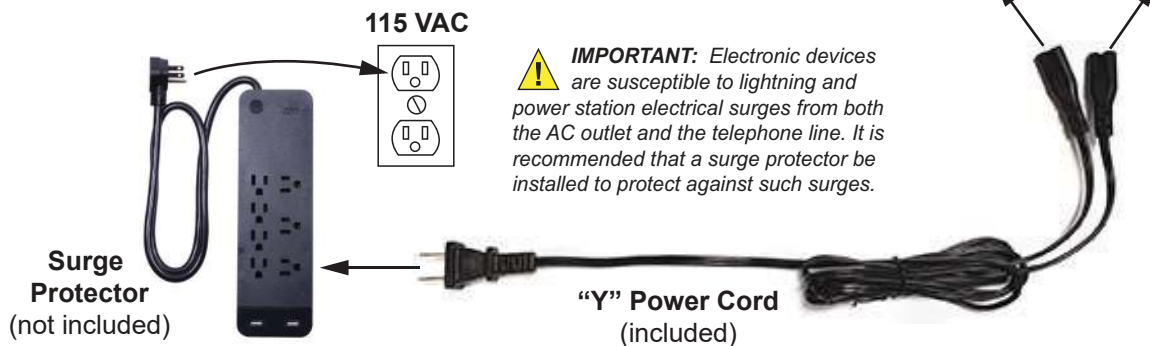

Programming

A. Accessing the Programming Mode

The **PA-250** can be programmed from any touch tone phone using a CO line, PABX analog station (FXS Port), PABX analog trunk input (FXO Port), or a Viking **DLE-200B** Line Simulator. Since phone system Paging Ports may not support touch tones, and also may not provide audio in both directions, programming the **PA-250** from a Paging Port is not recommended. For more information on the **DLE-200B**, see DOD 605.

1. Using the Security Code

Step 1	From a touch tone phone, access the PA-250 paging input in either the FXS or FXO mode (not paging port).
Step 2	When the page is made, enter a touch tone “*” (which will be heard through the paging speakers) then the 6-digit security code (factory set to 845464, see Programming section B). A double beep should be heard indicating you have entered the programming mode.

2. Without the Security Code

Step 1	Momentarily press the PROG button on the back of the unit using a small object such as a paperclip.
Step 2	Two beeps can be heard through the paging speakers and the front panel PAGE LED will flash for 20 seconds.
Step 3	During this 20 seconds of time, from a touch tone phone, access the PA-250 paging input in either the FXS or FXO mode (not paging port).
Step 4	A double beep should be heard in the phone indicating you have entered the programming mode.

B. Security Code (Memory Location #47)

The security code allows the user/installer to program the **PA-250**. The factory set security code is 845464 (V-I-K-I-N-G). It is recommended that the factory set security code be changed.

Example: To store 123456 as the security code:

Step 1.	Access programming as shown in Programming section A .
Step 2.	Enter 123456 #47 .
Step 3.	Continue programming other settings, or hang-up.

NOTE: The security code must be 6 digits and cannot include a “*” or a “#”.

C. Quick Programming Features

Description	Enter Digits	+	Memory Location
Microphone VOX Control (factory set to 0 = OFF)	0 or 1	then	#42
Page VOX Control (factory set to 0 = OFF)	0 or 1	then	#43
Input Priority (1 to 3, 1 = highest) (factory set to 312)	3 digits*	then	#44
Access Code (factory cleared, blank = Disabled)	0-6 digits	then	#45
Security Code (factory set to 845464)	6 digits	then	#47
Page Time Out (0 to 250 seconds, factory set to 0 = Disabled)	0 to 250	then	#48
VOX Silence Time Out (1 to 9 seconds, factory set to 3)	1-9	then	#49
Telecom Silence Time Out (0 to 9 seconds, factory set to 0 = Disabled)	0-9	then	#50
Chime Tone (1 to 4, factory set to 1 = door chime)	1-4	then	#51
Pre-Page Alert Tone = OFF (factory setting)	*0		
Pre-Page Alert Tone = ON	*1		
Busy Detect = OFF (factory setting)	*4		
Busy Detect = ON	*5		
Return to Dial Tone Detection = OFF (factory setting)	*6		
Return to Dial Tone Detection = ON	*7		
Dial Tone Generation = OFF (factory setting)	*8		
Dial Tone Generation = ON	*9		
Reset all programming to factory default settings	###		
Exit programming	#7		

* Inputs in this order: MIC IN (Microphone Input), PAGE INPUT (Telecom Page Input), AUX INPUT (Auxiliary Input).

NOTE: A double beep indicates a valid memory position, three beeps indicate an error.

D. Mic VOX Control

If a microphone that is connected to the **MIC INPUT** does not have a Push-to-Talk button, the Mic VOX Control feature should be enabled (enter **1#42** in programming). When enabled, the **PA-250** will trigger microphone paging when mic audio is detected.

NOTE: Pre-Page Alert Tone will not sound even if enabled.

E. Page VOX Control

If a paging port that is connected to the **PAGE INPUT** does not provide a contact closure for the **PAGE CONTACT** connections, the Page VOX Control feature should be enabled (enter **1#43** in programming). When enabled, the **PA-250** will trigger telecom paging when paging port audio is detected.

NOTE: Pre-Page Alert Tone will not sound even if enabled.

F. Input Priority

Since the **PA-250** has **MIC**, **PAGE** and **AUX** audio inputs, priorities are established to prevent contentions between the three. If multiple inputs are activated at the same time, the one with the highest priority will take effect. When any inputs share the same priority setting, they are considered “first come first served”. In other words, a second input will not interrupt a same priority input that is already actively paging.

The **PA-250** is factory set with the **PAGE** input set to “1”, which is the highest priority, so it has the ability to interrupt both the **MIC** and **AUX** audio inputs. The **AUX** input is factory set to “2”, and the **MIC** input is factory set to “3”, the lowest priority.

Each input can be programmed with a priority level from “1” down to “3”, so there is the ability to arrange any desired input priority for the Microphone, Telecom Page, and Auxiliary inputs. When in programming, to create a input priority sequence, enter a three digit string of numbers (followed by **#44**), that represent the priority level (from 1 to 3) of the inputs in this order: **MIC**, **PAGE** and **AUX** as shown below.

NOTE: The Background Music input will only be active when no other inputs are active. Loud ringing and Chime Tones will barge in.

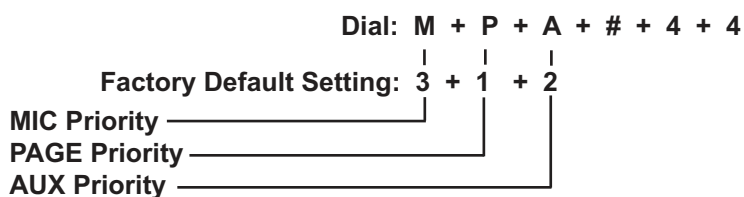

Enter Priority Settings Here:		
M	P	A
<input style="width: 30px; height: 20px;" type="text"/>	<input style="width: 30px; height: 20px;" type="text"/>	<input style="width: 30px; height: 20px;" type="text"/>
#44		

G. Access Code

When the **PAGE INPUT** is being used in either the FXO (Loop Start) or FSX (Ring Trip) modes, an Access Code can be set. When an Access Code is programmed, the incoming pager is prompted with a single beep. The pager is then required to enter the programmed 1 – 6 digit Access Code. If the proper access code is not entered within 6 seconds, the **PA-250** will triple beep and hang up or give a busy signal. When a valid Access Code has been entered, the **PA-250** will allow the page to pass through to the speakers.

To program an Access Code, enter **1-6** digits then **#45** in programming.

The **PA-250** is factory set with the Access Code disabled, which can be manually done by entering just **#45** in programming.

H. Page Time Out

A maximum page length of 1 to 250 seconds can be programmed for FXO (Loop Start), FXS (Ring Trip), Page Port using VOX mode, and Mic Page using VOX mode. When programmed, and the Page Time Out length has been met, the page will be terminated.

To program a Page Time Out, enter **1 - 250** then **#48** in programming.

The **PA-250** is factory set with the Page Time Out disabled so there is no paging time limit. Page Time Out can be manually disabled by entering just **#48** in programming.

NOTE: Not applicable with Mic paging when PTT is used, Page Port when Contact Closure is used, or the Aux Input.

I. VOX Silence Time Out

For the **AUX INPUT** and when the VOX mode is used for either Mic paging or Paging Port paging on the **PAGE INPUT**, the length of silence time required to end the page can be programmed from 1 – 9 seconds. The factory set time is 3 seconds, which means the page will end when no audio has been detected for 3 seconds.

To program VOX Silence Time Out, enter a single digit **1 to 9** then **#49** in programming.

J. Telecom Silence Time Out

For either the FXO (Loop Start) or FXS (Ring Trip) modes on the **PAGE INPUT**, a silence time (from 1 – 9 seconds), can be programmed to end the page. The **PA-250** is factory set with the Telecom Silence Time Out disabled.

FXO (Loop Start) paging will instantly end when the phone or Trunk Port hangs-up. If there is a potential risk of that not happening, the Telecom Silence Time Out can be used as a safety net to end the page.

FXS (Ring Trip) paging requires some sort of signaling from the phone system that the distant phone has hung up. The **PA-250** will hang up when it detects a CPC momentary open loop signal, (if the system provides it). If a CPC signal is not provided, but the system either returns to dial tone or a busy signal, the Return to Dial Tone Detection or Busy Detect feature should be enabled for the **PA-250** to be able to drop the page. If the system does not provide any of those, this Telecom Silence Time Out feature needs to be used. The page will simply end after the programmed amount of silence.

To program Telecom Silence Time Out, enter a single digit **1 to 9** then **#50** in programming.

Telecom Silence Time Out can be manually disabled by entering just **#50** in programming.

K. Chime Tone

One of four different sounds can be programmed for the Chime Tone that happens when a momentary contact closure is detected on the **CHIME TRIG** input. Program as shown right.

Loud Ringing Sound (Chime Tone)	In Programming Mode Enter
Door Chime (factory setting)	1#51
Double Gong	2#51
Quadruple Chime	3#51
Electronic Warble	4#51

L. Pre-Page Alert Tone

A short beep tone will be generated by the **PA-250** at the beginning of a MIC or Telecom page to help call attention to the upcoming announcement. If the page is initiated by VOX control, the Pre-Page Tone will not be generated so it does not beep on top of the voice page. The Pre-Page Alert Tone can be enabled and disabled in programming.

To disable the Pre-Page Alert Tone enter ***0** in programming (Factory Setting).

To enable the Pre-Page Alert Tone enter ***1** in programming.

M. Busy Detect and Return to Dial Tone Detection

FXS (Ring Trip) paging requires some sort of signaling from the phone system that the distant phone has hung up. The **PA-250** will hang up when it detects a CPC momentary open loop signal, (if the system provides it). If a CPC signal is not provided, but the system either returns to dial tone or a busy signal, the Return to Dial Tone Detection or Busy Detect feature should be enabled for the **PA-250** to be able to drop the page. If the system does not provide any of those, the Telecom Silence Time Out feature needs to be used. (See **Programming Section J**).

To disable the Busy Detect feature enter ***4** in programming (Factory Setting).

To enable the Busy Detect feature enter ***5** in programming.

To disable the Return to Dial Tone feature enter ***6** in programming (Factory Setting).

To enable the Return to Dial Tone feature enter ***7** in programming.

IMPORTANT: The front panel **PAGE** volume control needs to be turned up enough that Dial Tone or Busy signal brightly light up the **PAGE LED**.

N. Dial Tone Generation

This feature is factory disabled, and is only applicable when the Access Code feature is used. When Dial Tone Generation is enabled, the Access Code single beep prompt is replaced with 2 seconds of dial tone.

To disable the Dial Tone Generation feature enter ***8** in programming (Factory Setting).

To enable the Dial Tone Generation feature enter ***9** in programming.

A. Inputs

In the idle state, the **PA-250** allows Background Music to the speakers. When any of the three audio inputs are activated, background music is muted and the activated input is connected. Each input, except Background Music, has front panel LEDs that light up showing status of activity and audio level. If multiple inputs are activated, the **PA-250** will manage them however the Input Priority is programmed. Both Loud Ringing and Chime Tones will barge in on top of any active page. When no inputs are active, the **PA-250** will fade back to background music.

B. ALC Adjustment

The front panel **ALC** (Automatic Level Control), adjustment POT allows up to 6dB of dynamic audio compression. When used, it increases the level of soft spoken pages, and decreases the level of loud spoken pages. It is useful to help nominalize the volume of voice paging from both the Microphone and Telecom Page inputs. When dialed back to minimum, the **ALC** feature is disabled.

C. Bass and Treble Controls

Front panel **BASS** and **TREBLE** controls are provided to adjust the paging tonality. Since lower frequencies require higher power, turning the bass down can allow increased paging volume levels. Turning up the treble can increase paging intelligibility.

D. Master Volume Control and Peak Limiter

The front panel **MASTER VOLUME** control adjusts the volume coming from all inputs.

The **PA-250** has an integrated Peak Limiter feature that reduces the audio signal peaks by 4dB. Since audio signals are highly dynamic in nature, this feature allows the average volume level of pages to be 4dB louder than normal before clipping distortion occurs. The **MASTER VOLUME** LED blinks on when peak limiting is engaging. If maximum volume levels are desired, turn up the **MASTER VOLUME** control until the **MASTER VOLUME** LED starts blinking a bit during pages. Then use the 70V speaker taps to adjust the volume of each paging speaker, keeping in mind to NOT go over a total of 250 Watt accumulative load.

NOTE: *If audio sounds distorted, even when the volume is low enough that the **MASTER VOLUME** LED is not lighting up, the input circuitry for that source is probably being overdriven. Turn down the front panel trim pot for that input until the sound is clear.*

E. Power LED

The front panel **POWER** LED serves two purposes. It will light steady a few seconds after the unit is powered up showing power is applied. Second, it will momentarily wink off showing when the power amplifier is going into current limiting. If current limiting is observed, here is a list of suggested actions:

1	Turn down the input level of the specific input that is pushing it into current limiting.
2	Turn down the MASTER VOLUME level.
3	Turn down the BASS level.
4	Reduce the number of speakers connected to the PA-250 .
5	Reduce the power tap settings of the connected speakers.

Cost Effective Paging Horns and Speakers for 70V Paging Systems

In outdoor, factory or warehouse environments, **25AE-70V** paging horns are the best method of producing understandable sound. In these environments the directional design allows the installer to focus the sound cone down aisles and toward work areas.

The **25AE-70V** paging horn provides a built-in step-down transformer for use with 25V or 70V paging systems such as Viking models **PA-30**, **PA-60**, **PA-250**, **PA-250-IP** and **PP-250**. The transformer has a range of 5 separate switch selectable power taps, which can be used to adjust the volume of each speaker. These higher voltage distributed audio paging systems also have the advantage of being able to connect more speakers using lighter gauge wire runs while having less volume lost in wire resistance. This saves wiring costs compared to 8 Ohm systems. etc. For more info, see **DOD 471**.



**Model
25AE-70V**



Model 30AE-70V

In office and restaurant environments, it is best to distribute sound more evenly. Ceiling mounted **30AE-70V** speakers in close proximity offer the best distribution and are cost effective.

The **30AE-70V** ceiling speaker provides a built-in step-down transformer for use with 25V or 70V paging systems such as Viking models **PA-30**, **PA-60**, **PA-250**, **PA-250-IP** and **PP-250**. The transformer has a range of 5 separate power taps, which can be used to adjust the volume of each speaker. These higher voltage distributed audio paging systems also have the advantage of being able to connect more speakers using lighter gauge wire runs while having less volume lost in wire resistance. This saves wiring costs compared to 8 Ohm systems. For more info, see **DOD 473**.

High Power Weather Resistant Paging Horn for Use with 8 Ohm or 25V / 70V Systems

The **300AE** paging horn provides a built-in step-down transformer for use with 25V or 70V paging systems such as Viking models **PA-30**, **PA-60**, **PP-250**, **PA-250**, **PA-250-IP**. The transformer has a range of power taps that are selectable with a 6 position rotary switch, so that installers are able to independently adjust the volume of each paging horn. These higher voltage paging systems also have the advantage of being able to connect more speakers using lighter gauge wire runs and still have less volume lost in wire resistance.

The **300AE** weather resistant design allows for use in outdoor, factory, or warehouse environments. Its larger size and greater frequency response provide greater intelligibility of voice pages and is suitable for background music. The directional design allows the installer to focus the sound cone down aisles and toward work areas. The included mounting hardware provides full adjustment of horizontal and vertical positioning. For more info, see **DOD 497**.



**Model
300AE**

Tile Bridge for Ceiling Speakers

The **SA-TBA** is a tile bridge designed to mount 8 inch loud speaker and bridges both 2 ft x 2 ft and 2 ft x 4 ft ceiling tiles. It is compatible with the Viking models **SA-1S**, **30AE**, **35AE**, and **40AE** speakers. The **SA-TBA** tile bridge is constructed of 24 gauge cold rolled steel with an electro galvanized rust-resistant finish. For more info, see **DOD 534**.



**Model
SA-TBA**

Related Products

250 Watt / 70V Paging Power Amplifier



Model PP-250

For more info, see [DOD 511](#).

The **PP-250** is a 250 Watt 70V Paging Power Amplifier that can drive up to two hundred fifty (250) 70V speakers and/or paging horns (each speaker set to "1 Watt tap"). The small 1U rack size chassis is possible because the **PP-250** uses new amplifier technology that is 3 times more efficient than old designs competitors use. The high efficiency of the **PP-250** means much less heat dissipation, smaller size, higher reliability, and lower cost.

The **PP-250** can be used to add power amplification to a phone system paging port, Viking's remote access device (**RAD-1A**), clock controlled tone generators (**CTG-1A**, **CTG-2A**), mass notification announcer (**DNA-510**), digital announcers (**DVA-2WA**, **K-2000-DVA**), zone paging controller (**ZPI-4**), or to expand the paging power capability of these Viking products: **PA-IP**, **PA-2A**, **PA-15**, **PA-30**, **PA-250**, and **PA-250-IP**.

250 Watt / 70V SIP / Multicast Paging Amplifier



Model PA-250-IP

For more info, see [DOD 501](#).

The Viking model **PA-250-IP** SIP/Multicast Paging Amplifier provides up to 250 Watts of loud paging for SIP based VoIP phone systems (hardware or hosted/cloud based service provider). The **PA-250-IP** can be used for standard SIP endpoint paging or multicast paging.

The **PA-250-IP** can drive up to two hundred fifty (250) 70V speakers and/or paging horns (each speaker set to "1 Watt tap"). The small 1U rack size chassis is possible because the **PA-250-IP** uses new amplifier technology that is 3 times more efficient than old designs competitors use. The high efficiency of the **PA-250-IP** means much less heat dissipation, smaller size, higher reliability, and lower cost.

The unit easily connects with a single CAT5/6 cable from your network switch. The night ring feature is programmable for time of day and day of week to enable loud ringing for after hour incoming calls.

15 Watt Paging Amplifier with Background Music and Loud Ringing

The **PA-15** interfaces with virtually any telephone system to provide 15 Watts of paging power - enough to drive fifteen 8-Ohm paging horns or speakers. This small and light weight chassis design is possible by utilizing new amplifier technology that is 300% less inefficient than old designs competitors use. High efficiency means much less heat disipation, smaller size, higher reliability, and lower cost.

The **PA-15** provides 36V talk battery for interfacing with an **FXO** or unused analog line input/trunk port. With the flip of a switch, the unit can connect to a **FXS** or PABX/Centrex station ring trip port or connect to a 600 Ohm paging port. When interfacing with systems that do not provide a paging contact closure, the built-in voice activation (**VOX**) is in control.

For more information on the **PA-15**, see [DOD 486](#).



30 Watt Paging Amplifier with Background Music and Loud Ringing

The **PA-30** can directly drive up to thirty (30) 8 Ohm paging speakers or fifty (50) 70V or 25V paging speakers. This small and light weight chassis design is possible by utilizing new amplifier technology that is 300% less inefficient than old designs competitors use. High efficiency means much less heat disipation, smaller size, higher reliability, and lower cost.

The **PA-30** provides loud ringing and paging to electronic key systems, 1A2 Key systems, PABX's as well as No-KSU phones and multi-line phones. The **PA-30** eliminates the installation of multiple bells, relays and paging cards. The unit comes complete with a power supply, and integrated 30 Watt amplifier.

For more information on the **PA-30**, see [DOD 489](#).



60 Watt Compact Two Zone Amplifier to Drive 60 Paging Speakers

The **PA-60** can directly drive up to sixty (60) 8 Ohm paging speakers or one hundred (100) 70V or 25V paging speakers. Both channels can be fed the same input so the **PA-60** can be used as a single large amplifier, or each channel can be fed different inputs so the **PA-60** can be used as a two zone amplifier.

Since each input has its own gain adjustment, one zone can be turned up louder for warehouse paging horn speakers, and the other zone can be turned down for office ceiling speakers. Two zones can also be helpful for installations in which one group of speakers is connected to a source that provides background music using the Viking **PI-1A** Paging Interface unit, and the other zone provides only paging.

For more information on the **PA-60**, see [DOD 493](#).



Warranty

IF YOU HAVE A PROBLEM WITH A VIKING PRODUCT, CONTACT VIKING TECHNICAL SUPPORT: 715-386-8666

Our Technical Support Department is available for assistance Monday through Friday 8:00am to 5:00pm central time. Before you call, please:

1. Know the model number, the serial number and what software version you have (see serial label).
2. Have the Product Manual in front of you.
3. It is best if you are on site.

RETURNING PRODUCT FOR REPAIR

The following procedure is for equipment that needs repair:

1. Customer must contact Viking's Technical Support Department at 715-386-8666 to obtain a Return Authorization (RA) number. The customer MUST have a complete description of the problem, with all pertinent information regarding the defect, such as options set, conditions, symptoms, methods to duplicate problem, frequency of failure, etc.
2. Packing: Return equipment in original box or in proper packing so that damage will not occur while in transit. The original product boxes are not designed for shipping - an overpack box is required to prevent damage in transit. Static sensitive equipment such as a circuit board should be in an anti-static bag, sandwiched between foam and individually boxed. All equipment should be wrapped to avoid packing material lodging in or sticking to the equipment. Include ALL parts of the equipment. C.O.D. or freight collect shipments cannot be accepted. Ship cartons prepaid to:
**VIKING ELECTRONICS
1531 INDUSTRIAL STREET
HUDSON, WI 54016**
3. Return shipping address: Be sure to include your return shipping address inside the box. We cannot ship to a PO Box.
4. RA number on carton: In large printing, write the RA number on the outside of each carton being returned.

RETURNING PRODUCT FOR EXCHANGE

The following procedure is for equipment that has failed out-of-box (within 10 days of purchase):

1. Customer must contact Viking's Technical Support at 715-386-8666 to determine possible causes for the problem. The customer MUST be able to step through recommended tests for diagnosis.
2. If the Technical Support Product Specialist determines that the equipment is defective based on the customer's input and troubleshooting, a Return Authorization (RA) number will be issued. This number is valid for fourteen (14) calendar days from the date of issue.
3. After obtaining the RA number, return the approved equipment to your distributor. Please reference the RA number on the paperwork being shipped back with the unit(s), and also the outside of the shipping box. The original product boxes are not designed for shipping - an overpack box is required to prevent damage in transit. Once your distributor receives the package, they will replace the product over the counter at no charge. The distributor will then return the product to Viking using the same RA number.
4. **The distributor will NOT exchange this product without first obtaining the RA number from you. If you haven't followed the steps listed in 1, 2 and 3, be aware that you will have to pay a restocking charge.**

TWO YEAR LIMITED WARRANTY

Viking warrants its products to be free from defects in the workmanship or materials, under normal use and service, for a period of two years from the date of purchase from any authorized Viking distributor. If at any time during the warranty period, the product is deemed defective or malfunctions, return the product to Viking Electronics, Inc., 1531 Industrial Street, Hudson, WI., 54016. Customer must contact Viking's Technical Support Department at 715-386-8666 to obtain a Return Authorization (R.A.) number.

This warranty does not cover any damage to the product due to lightning, over voltage, under voltage, accident, misuse, abuse, negligence or any damage caused by use of the product by the purchaser or others. This warranty does not cover non-EWP products that have been exposed to wet or corrosive environments. This warranty does not cover stainless steel surfaces that have not been properly maintained.

NO OTHER WARRANTIES. VIKING MAKES NO WARRANTIES RELATING TO ITS PRODUCTS OTHER THAN AS DESCRIBED ABOVE AND DISCLAIMS ANY EXPRESS OR IMPLIED WARRANTIES OR MERCHANTABILITY OR FITNESS FOR ANY PARTICULAR PURPOSE.

EXCLUSION OF CONSEQUENTIAL DAMAGES. VIKING SHALL NOT, UNDER ANY CIRCUMSTANCES, BE LIABLE TO PURCHASER, OR ANY OTHER PARTY, FOR CONSEQUENTIAL, INCIDENTAL, SPECIAL OR EXEMPLARY DAMAGES ARISING OUT OF OR RELATED TO THE SALE OR USE OF THE PRODUCT SOLD HEREUNDER.

EXCLUSIVE REMEDY AND LIMITATION OF LIABILITY. WHETHER IN AN ACTION BASED ON CONTRACT, TORT (INCLUDING NEGLIGENCE OR STRICT LIABILITY) OR ANY OTHER LEGAL THEORY, ANY LIABILITY OF VIKING SHALL BE LIMITED TO REPAIR OR REPLACEMENT OF THE PRODUCT, OR AT VIKING'S OPTION, REFUND OF THE PURCHASE PRICE AS THE EXCLUSIVE REMEDY AND ANY LIABILITY OF VIKING SHALL BE SO LIMITED.

IT IS EXPRESSLY UNDERSTOOD AND AGREED THAT EACH AND EVERY PROVISION OF THIS AGREEMENT WHICH PROVIDES FOR DISCLAIMER OF WARRANTIES, EXCLUSION OF CONSEQUENTIAL DAMAGES, AND EXCLUSIVE REMEDY AND LIMITATION OF LIABILITY, ARE SEVERABLE FROM ANY OTHER PROVISION AND EACH PROVISION IS A SEPARABLE AND INDEPENDENT ELEMENT OF RISK ALLOCATION AND IS INTENDED TO BE ENFORCED AS SUCH.

FCC REQUIREMENTS

This equipment complies with Part 68 of the FCC rules and the requirements adopted by the ACTA. On the side of this equipment is a label that contains, among other information, a product identifier in the format US:AAEQ##TXXXX. If requested, this number must be provided to the telephone company.

The REN is used to determine the number of devices that may be connected to a telephone line. Excessive REN's on a telephone line may result in the devices not ringing in response to an incoming call. In most but not all areas, the sum of the REN's should not exceed five (5.0). To be certain of the number of devices that may be connected to a line, as determined by the total REN's, contact the local telephone company. For products approved after July 23, 2001, the REN for this product is part of the product identifier that has the format US:AAEQ##TXXXX. The digits represented by ## are the REN without a decimal point (e.g., 03 is a REN of 0.3). For earlier products, the REN is separately shown on the label.

The plug used to connect this equipment to the premises wiring and telephone network must comply with the applicable FCC Part 68 rules and requirements adopted by the ACTA. If your home has specially wired alarm equipment connected to the telephone line, ensure the installation of this PA-250 does not disable your alarm equipment. If you have questions about what will disable alarm equipment, consult your telephone company or a qualified installer.

If the PA-250 causes harm to the telephone network, the telephone company will notify you in advance that temporary discontinuance of service may be required. But if advance notice isn't practical, the telephone company will notify the customer as soon as possible. Also, you will be advised of your right to file a complaint with the FCC if you believe it is necessary.

The telephone company may make changes in its facilities, equipment, operations, or procedures that could affect the operation of the equipment. If this happens, the telephone company will provide advance notice in order for you to make the necessary modifications to maintain uninterrupted service.

If trouble is experienced with the PA-250, for repair or warranty information, please contact:

Viking Electronics, Inc., 1531 Industrial Street, Hudson, WI 54016 Phone: (715) 386-8666

If the equipment is causing harm to the telephone network, the telephone company may request that you disconnect the equipment until the problem is resolved.

Connection to Party Line Service is subject to State Tariffs. Contact the state public utility commission, public service commission or corporation commission for information.

WHEN PROGRAMMING EMERGENCY NUMBERS AND (OR) MAKING TEST CALLS TO EMERGENCY NUMBERS:

Remain on the line and briefly explain to the dispatcher the reason for the call. Perform such activities in the off-peak hours, such as early morning or late evenings.

It is recommended that the customer install an AC surge arrester in the AC outlet to which this device is connected. This is to avoid damaging the equipment caused by local lightning strikes and other electrical surges.

PART 15 LIMITATIONS

This equipment has been tested and found to comply with the limits for a Class A digital device, pursuant to Part 15 of the FCC Rules. These limits are designed to provide reasonable protection against harmful interference when the equipment is operated in a commercial environment. This equipment generates, uses, and can radiate radio frequency energy and, if not installed and used in accordance with the instruction manual, may cause harmful interference to radio communications. Operation of this equipment in a residential area is likely to cause harmful interference in which case the user will be required to correct the interference at his own expense.

Product Support: 715-386-8666

Due to the dynamic nature of the product design, the information contained in this document is subject to change without notice. Viking Electronics, and its affiliates and/or subsidiaries assume no responsibility for errors and omissions contained in this information. Revisions of this document or new editions of it may be issued to incorporate such changes.