

VIKING PRODUCT MANUAL

COMMUNICATION & SECURITY SOLUTIONS

PB-3**Emergency Phone
Panic Button**

November 15, 2019

Panic Button with User Recorded ID Message

Model **PB-3** is an Emergency Phone Panic Button designed to mount under a desk or countertop and provide a quick and reliable way to make a silent analog emergency call. The called party can silently monitor the situation or engage in two-way handsfree communication by entering a touch tone “#”.

The **PB-3** is designed to connect to any standard analog telephone line, analog phone system station or FXS port. All programming parameters, including phone numbers and location numbers, are stored in non-volatile memory. The unit is telephone line powered, requiring no batteries or external power, and is compatible with common Central Station Monitoring equipment.

The **PB-3** dials up to 5 emergency numbers, as well as 2 central station numbers, and can be easily programmed from any touch tone phone. The Panic Button can be programmed to automatically deliver a digital announcement identifying the location of the emergency call, and an optional DTMF touch tone code may also be delivered. The blue LED integrated into the push button will light, indicating that an emergency call is in progress.



Features

- **Automatic Noise Canceling (ANC) feature for clear audio in noisy environments**
- Non-volatile digital voice announcer with 16 seconds of voice memory
- Discreet compact design
- Built-in microphone for silent monitoring
- Advanced call progress detection
- Handsfree operation
- Phone line powered
- Non-volatile memory (no batteries required)
- Dials up to 5 emergency numbers
- Cycles through backup phone numbers on busy or no-answer
- Hangs up on CPC, silence, busy signal, dial tone or time-out
- Programmable to auto-answer on incoming calls
- Optional ID announcement
- Remotely programmable
- Extended temperature range (-15°F to 130°F)
- Central Station Monitoring capability (dials 2 numbers)
- Optional **PB-100** Polling System available (**DOD 232**)
- Optional **BLK-4-EWP** strobe light kit available (**DOD 654**)
- Optional **LC-6** Six Port Concentrator available (**DOD 245**)
- Also available with VoIP interface, see model **PB-3-IP** for more information (**DOD 241**)

Applications

- K-12 classrooms
- College classrooms
- Courtrooms
- Bank tellers
- Silent holdup alarm dialer
- Gas stations
- Motel reception desks
- Convenience stores
- All night restaurants

Specifications

Power*: Telephone line powered. Minimum 24V DC talk battery voltage, with a minimum loop current of 20mA loop. Loop current may be boosted on low current lines with a Viking model **TBB-1B** Talk Battery Booster (DOD 632).

Dimensions: See Installation and Specifications

Operating Temperature: -15° F to 130° F (-26° C to 54° C)

Humidity: 5% to 95% non-condensing

***CAUTION - When installing on an analog extension of a phone system:** Some phone systems do not conform to analog telecom standards and might not be compatible with the **PB-3** emergency phone. For a detailed description of the telephone line specifications required for the **PB-3** phone, see **DOD 869**.

www.VikingElectronics.com
Information: 715-386-8861

Wiring

⚠ IMPORTANT: Electronic devices are susceptible to lightning and power station electrical surges from both the AC outlet and the telephone line. It is recommended that a surge protector be installed to protect against such surges.

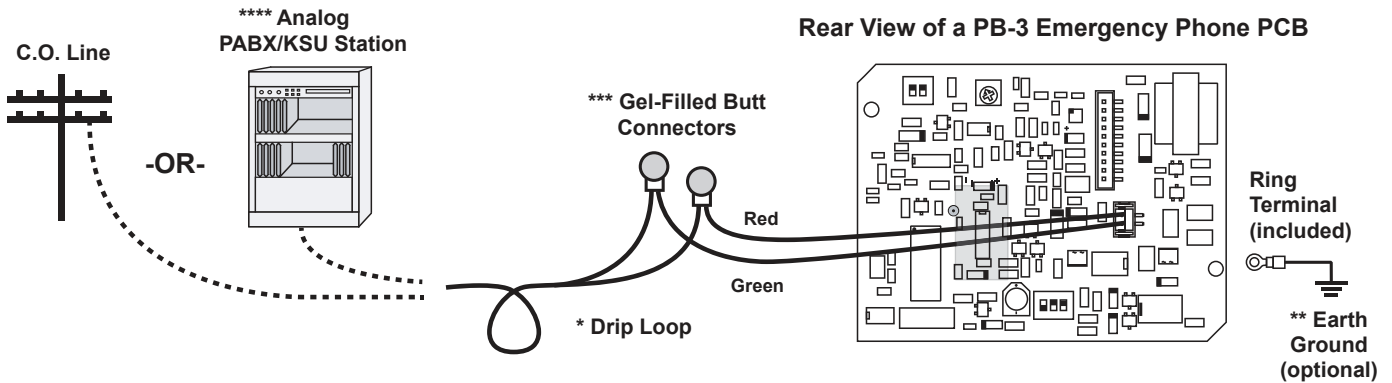

*** Note:** When wires are routed from above, a "drip loop" is recommended to keep water away from the circuit board.

***** Note:** The gel-filled (water-tight) butt connectors are designed for insulation displacement on 19-26 guage wire with a maximum insulation of 0.082 inches. Cut off bare wire ends prior to terminating.

**** Note:** To increase surge protection, loosen the PCB mounting screw labeled \oplus (as shown) and fasten a wire with ring terminal (included) from the mounting screw to Earth Ground (grounding rod, water pipe, etc.)

****** Note:** When installing a line powered phone on a low voltage and/or low loop current phone system extension, a **TBB-1B** Talk Battery Booster may be required. For more information on the **TBB-1B**, retrieve **DOD 632**.

Installation and Specifications

⚠ IMPORTANT: Electronic devices are susceptible to lightning from the telephone line. It is recommended that a surge protector be installed to protect against such surges.

Dimensions: 5.75" x 3.08" x 1.05" (146mm x 78mm x 27mm)
Material: 0.048" (18 Gauge) Steel
Finish: Black fine textured powder paint
Shipping Weight: 2.5 lbs. (1.3 kg)
Connections: Gel-filled butt connectors

Mounting: Surface mount under desks, under counter tops, to walls, posts or single gang electrical boxes
Note: For greater weather resistance, apply a bead of clear silicon caulking around the top edge and sides of the chassis.

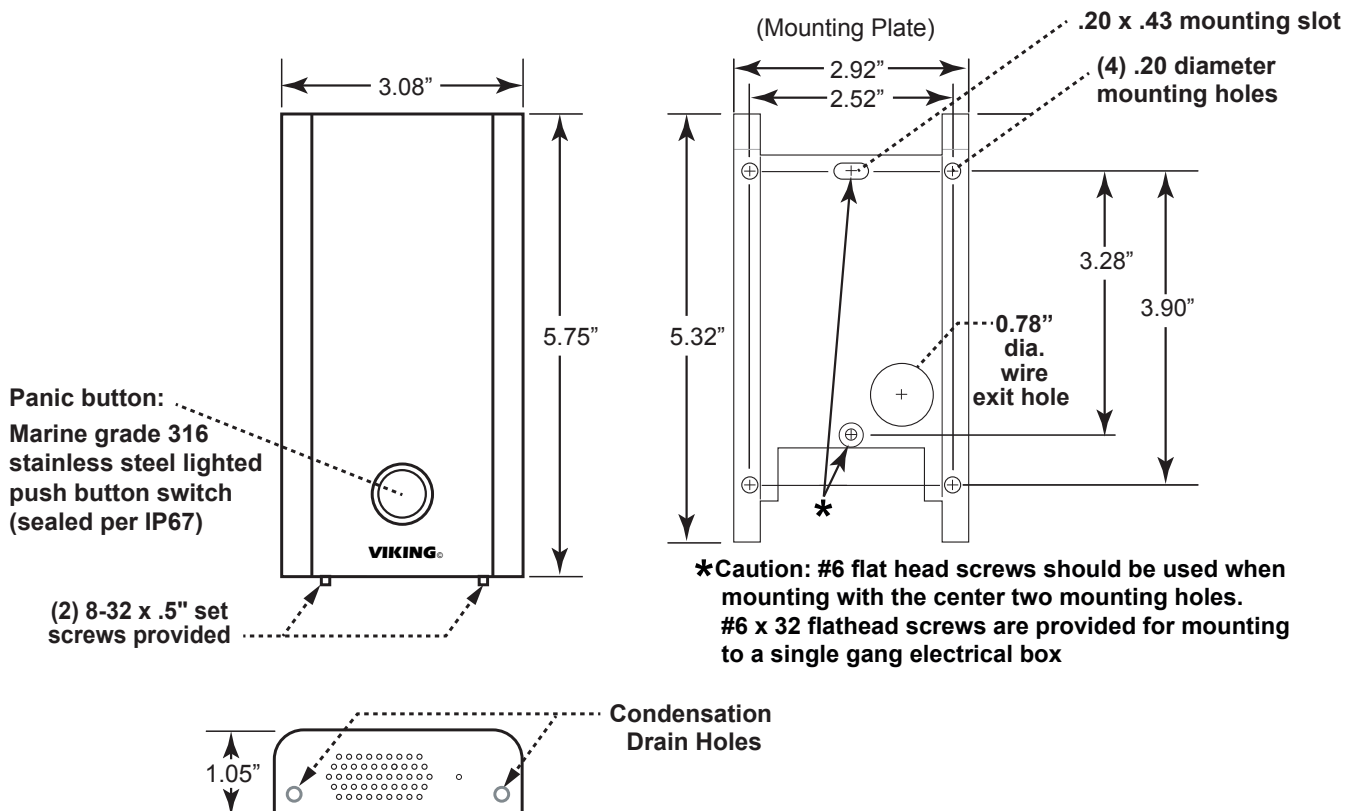

Programming

A. Accessing the Programming Mode

The **PB-3** emergency phone can be programmed from any Touch Tone phone using a C.O. line, analog PABX/KSU station, FXS port or a **DLE-200B** Line Simulator. For more information on the **DLE-200B**, see **DOD 605**.

1. Using the Security Code

Step 1.	Move DIP switch 2 to the ON position (sets unit to answer incoming calls, see section K).
Step 2.	From a Touch Tone phone call the line attached to the PB-3 phone.
Step 3.	When the PB-3 phone answers, enter the 6-digit security code (factory set to 845464 , see section B). A double beep should then be heard indicating you have entered the programming mode.

2. Without the Security Code

Step 1.	Move DIP switch 2 to the ON position (sets unit to answer incoming calls, see section K).
Step 2.	Move DIP switch 3 to the OFF position (incoming calls enter Programming without security code, see section K).
Step 3.	From a Touch Tone phone call the line attached to the PB-3 phone.
Step 4.	When the PB-3 answers, a double beep will be heard and will automatically enter the programming mode.
Step 5.	When finished programming, move DIP switch 3 back to the ON position (see section L).

Warning: Failure to do step 5 above will cause the **PB-3** phone to call Viking Technical Support instead of your programmed emergency number. See Section **L**, Assisted Programming.

B. Security Code (memory location #19)

The security code allows the user/installer to program the **PB-3** phone while DIP switch **3** is in the **ON** (normal) position. The factory set security code is 845464 (V-I-K-I-N-G). It is recommended that the factory set security code be changed.

Example: To store 654321 as the security code:

Step 1.	Access programming as shown in Programming section A .
Step 2.	Enter 654321 #19 .
Step 3.	Hang-up.

Enter Your Security Code Here:
<input type="text"/> <input type="text"/> <input type="text"/> <input type="text"/> <input type="text"/> <input type="text"/> <input type="text"/> #19

Note: The security code must be 6 digits and cannot include a * or a #.

C. Quick Programming Features

Description	Enter Digits	+	Memory Location
First emergency speed dial number	0-20 digits	then	#00
Second emergency speed dial number	0-20 digits	then	#01
Third emergency speed dial number	0-20 digits	then	#02
Fourth emergency speed dial number	0-20 digits	then	#03
Fifth emergency speed dial number	0-20 digits	then	#04
Central station receiver number	0-20 digits	then	#05
Central station voice number	0-20 digits	then	#06
Transmit ID number on inbound calls: 0 = Disable (factory setting), 1 = Enable	0 or 1	then	#15
Speaker Mode: 0 = OFF/Silent Monitor (factory setting), 1 = OFF until answered, 2 = ON	0, 1 or 2	then	#16
Voice announcer/miscellaneous options (factory set to 001210)	6 digits	then	#17
Timing/Dialing options (factory set to 230321)	6 digits	then	#18
Security code (factory set to 845464)	6 digits	then	#19
Identification number (factory cleared)	0-20 digits	then	#20
Second central station identification number (factory cleared)	0-20 digits	then	#21
Access Code (factory set to 123456)	0-6 digits	then	#23
To add a * at any point in the dialing string	**		
To add a # at any point in the dialing string	*#		
To add a four second pause at any point in the dialing string	*7		
To clear any speed dial number	(no digits)	then	#00 - #06
Diagnostic tones (used to check mic and speaker operation)	*0		
Exit programming and disconnect	#7		
Reset all programming to factory default settings	###		

Note: A double beep indicates a valid memory position, four beeps indicate an error.

D. Speed Dial Numbers

Note: Up to 20 digits can be stored in each dial position. Special features such as pause, mode change, touch tone * and # count as single digits.

1. Emergency Speed Dial Numbers (memory locations #00 - #04)

The emergency speed dial number programmed in location #00 is the number that is dialed when the "PANIC" button is first pressed. Additional speed dial numbers will be dialed when there is no answer or a busy signal is detected and the next number redial features are activated. To program, enter the desired speed dial number followed by the location number (#00 - #04). To clear a speed dial location, simply enter the memory location (#00 - #04) alone. The PB-3 phone is factory set with no speed dial number programmed.

To Program:	Enter:
*	**
#	*#
4 second pause	*7
0, 1, 2 9	0, 1, 2 9

2. Speed Dial Programming Examples

To Program the PB-3 Phone...	Step 1	Step 2
...to store 555-1234 as the first emergency speed dial number	Access Programming (see page 3)	Enter digits: 5 5 5 1 2 3 4 # 0 0
...to store a touch tone 9, a four second pause, and then 333-4444 into the second emergency speed dial memory position	Access Programming (see page 3)	Enter digits: 9 * 7 3 3 3 4 4 4 4 # 0 1
...to clear the first emergency speed dial number	Access Programming (see page 3)	Enter digits: # 0 0

E. Transmit ID Number on Inbound Calls (memory location #15)

With this feature enabled (1#15) the PB-3 will automatically transmit the DTMF ID number on all inbound calls. Transmission speed is 50msec on/off. If a # is entered within 5 seconds of the ID transmission this will force the unit to hang up. This location is not reset with ###. **Factory Setting:** Disabled, 0#15

F. Speaker Mode (memory location #16)

The Speaker Mode can be set to one of the following three modes.

OFF/Silent Monitoring Mode (Factory Setting): In the “OFF” mode (**0#16**) the speaker is disabled at all times. However, the speaker can be enabled after communication has been established by entering touch tone command “#”. The speaker will remain on for the duration of the call.

OFF Until Answered: In the “OFF Until Answered” mode (**1#16**) the speaker will remain silent during dialing and will not turn on until the called party has answered.

ON: In the “ON” mode (**2#16**) the speaker is enabled during In-bound and Out-bound calls.

G. Voice Announcer/Miscellaneous Options (memory location #17)

The PB-3 phones have a built-in non-volatile digital voice announcer that may be used to identify the location of the emergency phone call. The 16 seconds of digital record time is recorded remotely from a Touch Tone phone. Programming options are as follows:

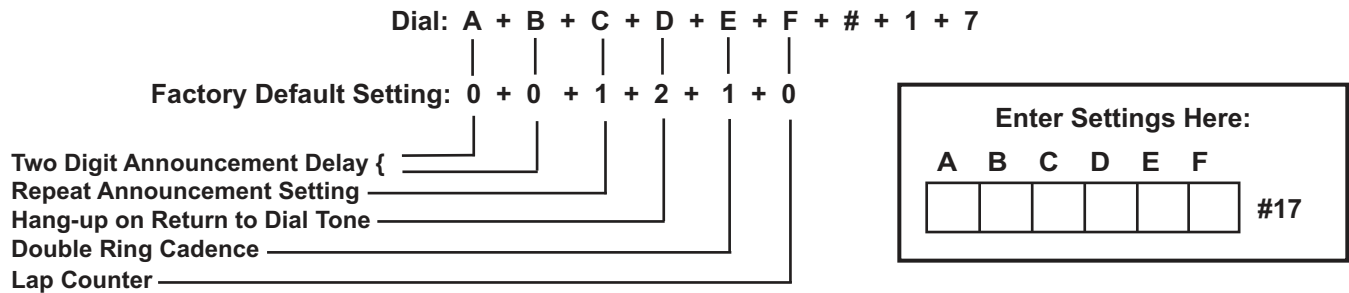

Settings A and B - Announcement Delay

The PB-3 phone is factory set to automatically start playing the voice announcement after it has determined the call has been answered. Alternately, the announcement may be programmed to play after a programmed amount of time, from 1 to 99 seconds after dialing. **Note:** *If the announcement delay time is used, you must allow enough time for the PB-3 phone to detect ring-no-answer and busy signals when using the redial features.* **Factory Setting:** Play automatically

Touch Tone	Setting A / B
00	Play automatically
01-99	1-99 seconds

Setting C - Repeat Announcement Option

The PB-3 can be programmed to play the announcement from 1-9 times, or to continuously repeat the announcement every 8 seconds until a Touch Tone Q is detected from the distant party. The call connected LED will turn on automatically after the announcement has stopped repeating. **Factory Setting:** Play the voice announcement 1 time

Touch Tone	Setting C
0	Repeat every 8 seconds
1-9	Play 1-9 times

Setting D - Hang Up on Return to Dial Tone

If enabled and a return dial tone is detected, the PB-3 will hang up. **Factory Setting:** Enabled

Touch Tone	Setting D
1	Disabled
2	Enabled

Setting E - Double Ring Cadence Mode

The PB-3 phone can be programmed to recognize the double ring cadence that is typical of many phone systems. If the PB-3 phone is connected to an extension that provides a double ring cadence, enabling this mode will allow for proper call progress detection. **Factory Setting:** Disabled

Touch Tone	Setting E
1	Disabled
2	Enabled

Setting F - Lap Counter

With the lap counter disabled, if the PB-3 phone is programmed to dial the next number on ring-no-answer and-or busy signal (see page 8), the PB-3 phone will continuously call its programmed phone numbers forever until the phone is answered. The lap counter is a programmable counter that determines how many times the PB-3 phone will cycle through its list of up to 5 emergency phone numbers, before it stops the dialing process and hangs up. When all the programmed phone numbers have been dialed, the lap counter is incremented and the dialing process repeats. When the lap counter has been met, the dialing process stops and the PB-3 phone hangs up. **Factory Setting:** Disabled

Touch Tone	Setting F
0	Disabled
1-9	Lap count: 1-9 times

H. Recording the Announcement

Step 1	Call into the PB-3 phone with a Touch Tone phone and access the programming mode as shown on page 3.
Step 2	Enter *4, wait for the tone and then begin recording. Note: <i>There are 16 seconds of record time is available.</i>
Step 3	Enter any Touch Tone to stop the recording. Note: <i>Playback is automatic.</i>
Step 4	Enter *5 to review the announcement again.
Step 5	If you choose to not use a voice announcement, enter *3 to clear the recording.

Example: “Elevator number 1215, located in the Financial Building, needs assistance. Press the asterisk (*) key on your telephone to hear this announcement again.”

I. Timing/Dialing Options (memory location #18)

There are six positions in the timing/dialing options. To program these options, enter the six desired timing/dialing numbers followed by #18. The six available timing/dialing options are defined as follows:

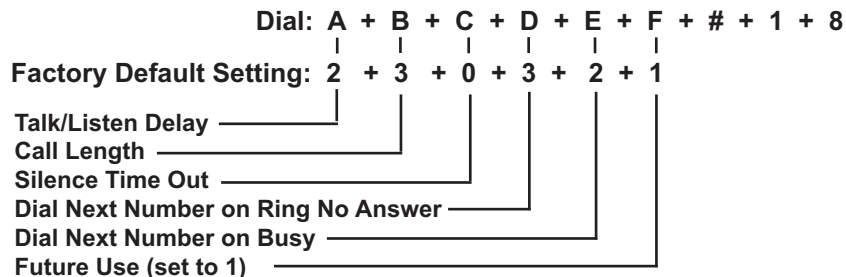

Enter Timing/Dialing Settings Here:

A	B	C	D	E	F	
						#18

Setting A - Talk/Listen Delay

This feature selects switching time between talk and listen modes (VOX switching time). Use chart below-left.

Factory Setting: 0.2 seconds

Setting B - Call Length Time Out

This feature selects the maximum length of time that calls can be connected. Programmable in increments of 1 minute up to a maximum of 9 minutes (Touch Tones 1 - 9). Program 0 in this location to disable the call length time out. With the call length disabled, the **PB-3** phone must rely on a CPC signal, busy signal, silence or return to dial tone to hang-up. Use chart below - center. **Factory Setting:** 3 Minutes

Setting C - Silence Time Out

This feature selects the length of time that calls will remain connected without voice activity. Programmable in increments of 10 seconds up to a maximum of 90 seconds (Touch Tones 1 - 9). To disable the silence time out, program 0 in this location. Use chart below - right. **Factory Setting:** Disabled

Touch Tone	Talk/Listen Delay
1	0.1 seconds
2	0.2 seconds
3	0.3 seconds
4	0.4 seconds
5	0.5 seconds
6	0.6 seconds
7	0.7 seconds
8	0.8 seconds
9	0.9 seconds

Touch Tone	Call Length Time Out
0	Disabled
1	1 minute
2	2 minutes
3	3 minutes
4	4 minutes
5	5 minutes
6	6 minutes
7	7 minutes
8	8 minutes
9	9 minutes

Touch Tone	Silence Time Out
0	Disabled
1	10 seconds
2	20 seconds
3	30 seconds
4	40 seconds
5	50 seconds
6	60 seconds
7	70 seconds
8	80 seconds
9	90 seconds

Setting D - Dial Next Number on Ring No Answer

If enabled and a ring-no-answer is detected, the **PB-3** phone will dial the next programmed speed dial number, and continue to cycle through the emergency numbers until a call is completed.

Factory Setting: Redial if not answered after 3 rings

Touch Tone	Setting D
1 or 0	Disabled
2, 3, 4...9	Dials second number after 2, 3, 4...9 rings respectively

Setting E - Dial Next Number on Busy

If enabled and a busy is detected, the **PB-3** phone will dial the next programmed speed dial number, and continue to cycle through the numbers until a call is completed.

Factory Setting: Enabled **Note:** If the busy signal is interrupted with a promotional message, contact your central office to have it removed.

Touch Tone	Setting E
1	Disabled
2	Enabled

Setting F - Future Use (set to 1)

J. Identification Number (memory location #20)

The Touch Tone I.D. number (up to 20 digits) is used by emergency personnel to identify the location of the caller and is given out when the receiving party presses a Touch Tone *. The security office can display the number using a Touch Tone decoder. To program the I.D. number, enter the desired number followed by #20. **Example:** To store 333 as the I.D. number, enter: **3 3 3 # 2 0**

Note: With transmit ID on Inbound calls enable (1 #15), the PB-3 will automatically transmit the touch tone ID number on all inbound calls.

K. Access Code

The access code is for adding security to inbound calls. With an access code programmed, callers will be required to enter a 1 to 6 digit access code before the unit will go into two-way communications or silent monitoring.

The code can be 1 – 6 digits in length and cannot contain a "*" or "#" or match the numbers used for the security code. Simply call the PB-3 emergency phone, the unit will automatically answer the line and output one beep. You can then enter the programmed 1 - 6 digit access code, 2 beeps should be heard. With the speaker mode in "OFF until answered" or "ON" mode, you now will have two-way communication with the PB-3. With the speaker mode in "OFF/Silent Monitor" mode, you can then silently monitor the PB-3's microphone audio or break into two-way communications by entering a touch tone "#".

If this additional level of security is not required, the access code can be cleared in programming by entering #23 with no preceding digits. **Factory Setting:** 123456

L. Assisted Programming

When attempting to program the PB-3 emergency phone, if the phone number of the line it is connected to is not known, the phone can be set to automatically call Viking technical support for assistance. With DIP switch 3 set to OFF (programming mode), pushing the CALL button will cause the PB-3 phone to call Viking, whether it be connected directly to a CO line, or behind a "dial 9" PBX.

The PB-3 phone will first dial 9, and then listen for second dial tone; if detected it will continue to dial Viking's assisted programming phone number. If a second dial tone is not detected, it then knows it is not behind a PBX, so it will momentarily hang up and then directly dial Viking's assisted programming phone number. Since this is a long distance phone call, the line must be capable of placing long distance calls for the call to go through. When finished programming, it is very important to set DIP switch 3 back to ON (normal operating mode), and place a test emergency call to be sure all programming was done properly.

Warning: Failure to set DIP switch 3 back to ON when finished programming will cause the PB-3 phone to call Viking Technical Support, instead of your programmed emergency number. Yet, as a fail-safe measure, after 3 calls to Viking, the unit will ignore switch 3 and dial its programmed phone numbers.

M. DIP Switch Programming/Speaker and Microphone Adjustments

A speaker volume POT is provided to increase or decrease the speakerphone volume. **Note:** The Microphone Sensitivity POT has been removed because the microphone sensitivity is now microprocessor controlled. This allows the mic gain to be automatically increased in a quiet environment, allowing the distant party to clearly hear even soft or distant sounds. The microprocessor will automatically reduce the mic sensitivity when the location becomes noisy. This Automatic Noise Canceling (ANC) feature will allow speakerphone two-way communications to continue to work properly, even when subjected to loud noise such as a diesel engine or traffic.

Switch A	Switch B	Description
ON	ON	Normal audio detection
OFF	OFF	Increase audio detect sensitivity for low level lines. Useful in applications in which voice or busy signals have trouble breaking over the speaker.

Switch	Position	Description
1	ON	"PANIC" button alternately connects/disconnects calls
1	OFF	"PANIC" button connects calls only (Factory Setting)
2	ON	Incoming calls answered (Factory Setting)
2	OFF	Incoming calls are not answered
3	ON	Normal operation mode (Factory Setting)
3	OFF	Learn mode - Any incoming calls are automatically entered into the programming mode (no security code required). Use this option if you have forgotten your security code. Any outbound call will dial Viking Technical Support (see section K). Warning: When finished programming, set this switch back to the ON position, otherwise the PB-3 phone will only call Viking Technical Support instead of your programmed emergency number.

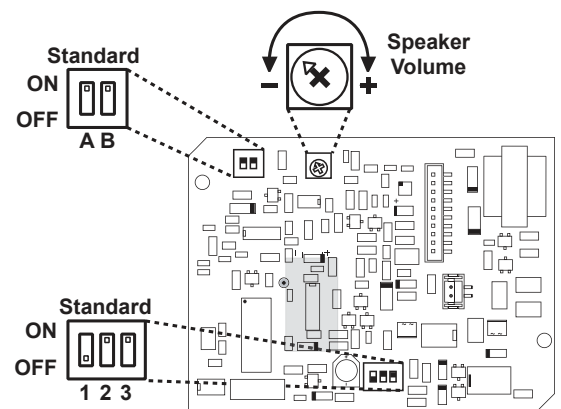

N. Central Station Programming

The **PB-3** emergency phone is capable of communicating using the “Ademco Contact I.D.”, “Ademco High Speed”, “DTMF 4+1 Express”, or the “DTMF 4+2 Express” formats. All formats use the programming memory location **#20** to store the account code and alarm details.

1. Central Station Programming Features

a. Accessing the Programming Mode

Before programming, you must access the programming mode (see **Programming** section **A**).

b. Enabling/Disabling Central Station Mode

The **PB-3** emergency phone can be placed in the “Central Station Mode” by entering a central station phone number in position **#05** while programming. To cancel the “Central Station Mode,” clear position **#05** by entering **#05** only (see **Programming** section **D**).

To Program the PB-3 Phone...	Step 1:	Step 2 - Enter Digits:
...to enable central station programming and dial 952-2567	Enter Programming (see page 3)	9 5 2 2 5 6 7 # 0 5
...to disable central station programming	Enter Programming (see page 3)	# 0 5

c. Ring No Answer

When the **PB-3** emergency phone is in the “Central Station Mode”, it is best to have the ring no answer set to a minimum of three, because some receivers send a long tone after answering the line that sounds like a ring back. If the **PB-3** is set to a ring no answer of two, the phone will disconnect (see **Programming** section **J**).

d. Speed Dial Numbers

The **PB-3** phone can be programmed to dial a central station receiver only, or dial up to 5 voice numbers first, and if no answer, then dial the central station receiver. When calling the first numbers (memory positions **#00-#04** (see **Programming** section **D**), the phone stays in “two-way talk mode” allowing two-way conversation. When calling the Central Station number (memory position **#05**), the phone is in a “listen only mode” in order to interpret the hand shake signals of the receiver.

A second central station number position has been provided in location **#06** that is used when the central station receiver does not have a talk over mode. If a number is placed in position **#05** and position **#06** is cleared, the **PB-3** will call the central station monitor receiver. One or two alarm messages can be sent to the receiver (see **Operation** section **B**, note **3**). After the receiver sends a kiss-off, the **PB-3** lights the “panic button” LED and goes into two-way talk mode. If numbers are in both positions **#05** and **#06**, the **PB-3** will call the receiver first, and after the kiss-off, will hang-up and redial the number in position **#06** for two-way voice communication.

Location	Call Type
#00	Voice - Emergency
#01	Voice - Emergency
#02	Voice - Emergency
#03	Voice - Emergency
#04	Voice - Emergency
#05	Central Station Receiver
#06	Central Station Voice Line

Note: If only a central station is to be dialed, the central station phone number must be preprogrammed in memory location **#05** and memory locations **#00-#04** must be cleared.

2. Central Station Formats

The following examples explain the receiver formats and how to properly program memory location **#20**. Each format starts with a four digit account code. This is the code that is assigned by your central station for billing purposes. You must access the programming mode before programming these features (see **Programming** section **A**). **Important:** If a number is shown, you must use that number. If an “**X**” is shown, use any appropriate number. **Note:** A second information alarm message can be sent to the receiver, for any receiver that requires two separate messages. The second alarm message is programmed in **#21** location. For additional information about the second alarm message, see **Operation** section **B**.

Ademco Contact ID Format	XXXX	18	1	14000	XXX	#20
This DTMF format consists of a four digit account code, two digit message type, and a nine digit data field.	Account Code	Message Type	New Event	General Alarm	Number to identify phone	Memory Location
Enter Contact ID Settings Here:	____	18	1	14000	___	#20

Sometimes the central station receiver requires a secondary “listen-in to follow” code to be sent. This can be accomplished by programming memory location #21 as shown right. * Note: Set the account code and the identifier the same as memory location #20 .	XXXX *Account Code	18 Message Type	1 New Event	60600 Listen-In to Follow	XXX *Number to identify phone	#21 Memory Location
---	------------------------------	---------------------------	-----------------------	-------------------------------------	---	-------------------------------

Ademco High Speed Format	XXXX	55	1	55555	7	#20
This DTMF format consists of a four digit account code, eight zone codes and one alarm type digit. With this format you can identify up to eight different phones by using a zone per phone. A "5" in a zone position means no alarm. The following example shows an alarm from the third phone.	Account Code	Idle Zones	Alarmed Zone	Idle Zones	Normal Alarm	Memory Location
Enter Ademco High Speed IP Settings Here:	___	55	1	55555	7	#20

4+1 Express Format	XXXX	17	X	#20
This DTMF format consists of a four digit account code, two digit message type, and a single digit event code.	Account Code	Message Type	Event Code	Memory Location
Enter 4+1 Express ID Settings Here:	___	17	—	#20

4+2 Express Format	XXXX	27	XX	#20
This DTMF format consists of a four digit account code, two digit message type, and a two digit event code.	Account Code	Message Type	Event Code	Memory Location
Enter 4+2 Express ID Settings Here:	___	27	—	#20

Operation

A. Standard Operation

When the "PANIC" button is pressed, the PB-3 Emergency phone goes off-hook and dials a pre-programmed telephone number. The Panic button LED momentarily flashes during tone or pulse dialing. In the event the line is busy or there is a ring-no-answer, the unit can be programmed to call additional phone numbers.

The phone then cycles through up to 5 pre-programmed emergency numbers until the call is answered. When the call is answered, the digital voice announcer will automatically play to identify the location of the emergency call. The phones are factory programmed to play the announcement once, and then automatically light the Panic button LED to show that handsfree communication to emergency personnel is established. The * key will send the I.D. number (if programmed), and play the announcement again. The distant party will know the location of the emergency call by either the voice announcement or by decoding the Touch Tone I.D. number. After answering the call, the distant party can silently monitor the situation then enter a touchtone "#" to enable two way communications with the PB-3 speaker phone.

B. Central Station Operation

After the "PANIC" button on the PB-3 phone has been pressed the PB-3 phone will begin to dial. If a voice number is programmed in memory locations #00-#04, these numbers will be dialed first. Upon detecting a busy signal or after a preprogrammed ring delay the PB-3 phone will hang-up and dial the central station phone number stored in memory location #05. When the central station receiver answers, it will send a handshake tone to the PB-3 phone. Upon detecting the handshake tone, the PB-3 phone will begin uploading the information stored in memory location #20.

Once the PB-3 emergency phone has sent the information stored in memory location #20, it waits for a "kiss-off" tone from the central station. When the "kiss-off" tone is received, the emergency phone turns on the call connected LED and goes into the "two-way talk mode" or hangs up and dials position #06 if programmed (see Note 3 below).

- Notes:**
1. The central station should have a "talk-over" feature that will allow a two-way conversation at this time. If your receiver does not support "talk-over", a voice phone number should be programmed into position #06.
 2. If the central station answers the call, sends the handshake tone, but does not send a "kiss off" tone after the information is sent, the PB-3 resends the information three additional times, waiting for a "kiss-off" after each attempt. If "kiss-off" has not been received after the fourth attempt, the PB-3 hangs up and dials position #06 again.
 3. The PB-3 has the capability to send a second informational message to the receiver after the first "kiss-off" is received, but only if a second informational message is stored in memory location #21. After the first "kiss-off" is received, the PB-3 sends the information stored in memory location #21. It then waits for a second "kiss-off" from the central station receiver. When the second "kiss-off" is received, the emergency phone turns on the call connected LED and goes into the "two-way talk mode" or hangs up and dials position #06 if programmed.

Related Products

Model **PB-3-IP** is an VoIP Emergency Phone Panic Button designed to mount under a desk or countertop and provide a quick and reliable way to make a silent emergency call. The called party can silently monitor the situation or engage in two-way handsfree communication by entering a touch tone “#”.

The **PB-3-IP** functions as a SIP end point connecting with a single CAT 5/6 cable from your POE switch. The unit can be programmed from any PC on the same LAN or remotely using a static IP address.

The **PB-3-IP** dials up to 5 emergency numbers and can be easily programmed from any touch tone phone. The Panic Button can be programmed to automatically deliver a digital announcement identifying the location of the emergency call, and an optional DTMF touch tone code may also be delivered. The blue LED integrated into the push button will light, indicating that an emergency call is in progress.

For more Information, see DOD 241.



Warranty

IF YOU HAVE A PROBLEM WITH A VIKING PRODUCT, CONTACT: VIKING TECHNICAL SUPPORT AT 715-386-8666

Our Product Support Department is available for assistance Monday - Friday 8am - 5pm central time. So we can give you better service, before you call please:

1. Know the model number, the serial number and what software version you have (see serial label).
2. Have your Product Manual in front of you.
3. It is best if you are on site.

RETURNING PRODUCT FOR REPAIR

The following procedure is for equipment that needs repair:

1. Customer must contact Viking's Technical Support Department at 715-386-8666 to obtain a Return Authorization (R.A) number. The customer MUST have a complete description of the problem, with all pertinent information regarding the defect, such as options set, conditions, symptoms, methods to duplicate problem, frequency of failure, etc.
2. Packing: Return equipment in original box or in proper packing so that damage will not occur while in transit. Sensitive equipment such as a circuit board should be in an anti-static bag, sandwiched between foam and individually boxed. All equipment should be wrapped to avoid packing material lodging in or sticking to the equipment. Include ALL parts of the equipment. C.O.D. or freight collect shipments cannot be accepted. Ship cartons prepaid to: **Viking Electronics, 1531 Industrial Street, Hudson, WI 54016**
3. Return shipping address: Be sure to include your return shipping address in the box. We cannot ship to a PO Box.
4. RA number on carton: In large printing, write the R.A. number on the outside of each carton being returned.

RETURNING PRODUCT FOR EXCHANGE

The following procedure is for equipment that has failed out-of-box (within 10 days of purchase):

1. Customer must contact Viking's Technical Support at 715-386-8666 to determine possible causes for the problem. The customer MUST be able to step through recommended tests for diagnosis.
2. If the Technical Support Product Specialist determines that the equipment is defective based on the customer's input and troubleshooting, a Return Authorization (R.A.) number will be issued. **This number is valid for fourteen (14) calendar days from the date of issue.**
3. After obtaining the R.A. number, return the approved equipment to your distributor, referencing the R.A. number. Your distributor will then replace the Viking product using the same R.A. number.
4. **The distributor will NOT exchange this product without first obtaining the R.A. number from you. If you haven't followed the steps listed in 1, 2 and 3, be aware that you will have to pay a restocking charge.**

TWO YEAR LIMITED WARRANTY

Viking warrants its products to be free from defects in the workmanship or materials, under normal use and service, for a period of two years from the date of purchase from any authorized Viking distributor. If at any time during the warranty period, the product is deemed defective or malfunctions, return the product to Viking Electronics, Inc., 1531 Industrial Street, Hudson, WI, 54016. Customer must contact Viking's Technical Support Department at 715-386-8666 to obtain a Return Authorization (R.A.) number.

This warranty does not cover any damage to the product due to lightning, over voltage, under voltage, accident, misuse, abuse, negligence or any damage caused by use of the product by the purchaser or others. This warranty does not cover non-EWP products that have been exposed to wet or corrosive environments. This warranty does not cover stainless steel surfaces that have not been properly maintained.

NO OTHER WARRANTIES. VIKING MAKES NO WARRANTIES RELATING TO ITS PRODUCTS OTHER THAN AS DESCRIBED ABOVE AND DISCLAIMS ANY EXPRESS OR IMPLIED WARRANTIES OR MERCHANTABILITY OR FITNESS FOR ANY PARTICULAR PURPOSE.

EXCLUSION OF CONSEQUENTIAL DAMAGES. VIKING SHALL NOT, UNDER ANY CIRCUMSTANCES, BE LIABLE TO PURCHASER, OR ANY OTHER PARTY, FOR CONSEQUENTIAL, INCIDENTAL, SPECIAL OR EXEMPLARY DAMAGES ARISING OUT OF OR RELATED TO THE SALE OR USE OF THE PRODUCT SOLD HEREUNDER.

EXCLUSIVE REMEDY AND LIMITATION OF LIABILITY. WHETHER IN AN ACTION BASED ON CONTRACT, TORT (INCLUDING NEGLIGENCE OR STRICT LIABILITY) OR ANY OTHER LEGAL THEORY, ANY LIABILITY OF VIKING SHALL BE LIMITED TO REPAIR OR REPLACEMENT OF THE PRODUCT, OR AT VIKING'S OPTION, REFUND OF THE PURCHASE PRICE AS THE EXCLUSIVE REMEDY AND ANY LIABILITY OF VIKING SHALL BE SO LIMITED.

IT IS EXPRESSLY UNDERSTOOD AND AGREED THAT EACH AND EVERY PROVISION OF THIS AGREEMENT WHICH PROVIDES FOR DISCLAIMER OF WARRANTIES, EXCLUSION OF CONSEQUENTIAL DAMAGES, AND EXCLUSIVE REMEDY AND LIMITATION OF LIABILITY, ARE SEVERABLE FROM ANY OTHER PROVISION AND EACH PROVISION IS A SEPARABLE AND INDEPENDENT ELEMENT OF RISK ALLOCATION AND IS INTENDED TO BE ENFORCED AS SUCH.

FCC REQUIREMENTS

This equipment complies with Part 68 of the FCC rules and the requirements adopted by the ACTA. On the side of this equipment is a label that contains, among other information, a product identifier in the format US:AAEQ##TXXXX. If requested, this number must be provided to the telephone company.

The REN is used to determine the number of devices that may be connected to a telephone line. Excessive REN's on a telephone line may result in the devices not ringing in response to an incoming call. In most but not all areas, the sum of the REN's should not exceed five (5.0). To be certain of the number of devices that may be connected to a line, as determined by the total REN's, contact the local telephone company. For products approved after July 23, 2001, the REN for this product is the product identifier that has the format US:AAEQ##TXXXX. The digits represented by ## are the REN without a decimal point (e.g., 03 is a REN of 0.3). For earlier products, the REN is separately shown on the label.

The plug used to connect this equipment to the premises wiring and telephone network must comply with the applicable FCC Part 68 rules and requirements adopted by the ACTA. If your home has specially wired alarm equipment connected to the telephone line, ensure the installation of this PB-3 phone does not disable your alarm equipment. If you have questions about what will disable alarm equipment, consult your telephone company or a qualified installer.

If the PB-3 phone causes harm to the telephone network, the telephone company will notify you in advance that temporary discontinuance of service may be required. But if advance notice isn't practical, the telephone company will notify the customer as soon as possible. Also, you will be advised of your right to file a complaint with the FCC if you believe it is necessary.

The telephone company may make changes in its facilities, equipment, operations, or procedures that could affect the operation of the equipment. If this happens, the telephone company will provide advance notice in order for you to make the necessary modifications to maintain uninterrupted service.

If trouble is experienced with the PB-3 phone, for repair or warranty information, please contact:

Viking Electronics, Inc., 1531 Industrial Street, Hudson, WI 54016 (715) 386-8666

If the equipment is causing harm to the telephone network, the telephone company may request that you disconnect the equipment until the problem is resolved. Connection to Party Line Service is subject to State Tariffs. Contact the state public utility commission, public service commission or corporation commission for information.

WHEN PROGRAMMING EMERGENCY NUMBERS AND (OR) MAKING TEST CALLS TO EMERGENCY NUMBERS: Remain on the line and briefly explain to the dispatcher the reason for the call. Perform such activities in the off-peak hours, such as early morning or late evenings.

It is recommended that the customer install an AC surge arrester in the AC outlet to which this device is connected. This is to avoid damaging the equipment caused by local lightning strikes and other electrical surges.

PART 15 LIMITATIONS

This equipment has been tested and found to comply with the limits for a Class A digital device, pursuant to Part 15 of the FCC Rules. These limits are designed to provide reasonable protection against harmful interference when the equipment is operated in a commercial environment. This equipment generates, uses, and can radiate radio frequency energy and, if not installed and used in accordance with the instruction manual, may cause harmful interference to radio communications. Operation of this equipment in a residential area is likely to cause harmful interference in which case the user will be required to correct the interference at his own expense.

Product Support: 715-386-8666

Due to the dynamic nature of the product design, the information contained in this document is subject to change without notice. Viking Electronics, and its affiliates and/or subsidiaries assume no responsibility for errors and omissions contained in this information. Revisions of this document or new editions of it may be issued to incorporate such changes.